



Wastewater Energy Transfer (WET) Heat Recovery Systems Market Study

Final Report
ET25SWE0021



Prepared by:

Gretchen Schimelpfenig, PE ERI
Ethan Clifford, PE ERI

January 22, 2026

Acknowledgements

The project team engaged numerous stakeholders in the production and review of this final report, and wishes to acknowledge the contributions of the following organizations:

- Energy Solutions
- Pacific Gas & Electric (PG&E)
- San Diego Gas & Electric (SDG&E)
- Southern California Edison (SCE)
- Participating PG&E, SDG&E, and SCE customers
- SHARC Energy

Disclaimer

The CalNEXT program is designed and implemented by Cohen Ventures, Inc., DBA Energy Solutions (“Energy Solutions”). Southern California Edison Company, on behalf of itself, Pacific Gas and Electric Company, and San Diego Gas & Electric® Company (collectively, the “CA Electric IOUs”), has contracted with Energy Solutions for CalNEXT. CalNEXT is available in each of the CA Electric IOU’s service territories. Customers who participate in CalNEXT are under individual agreements between the customer and Energy Solutions or Energy Solutions’ subcontractors (Terms of Use). The CA Electric IOUs are not parties to, nor guarantors of, any Terms of Use with Energy Solutions. The CA Electric IOUs have no contractual obligation, directly or indirectly, to the customer. The CA Electric IOUs are not liable for any actions or inactions of Energy Solutions, or any distributor, vendor, installer, or manufacturer of product(s) offered through CalNEXT. The CA Electric IOUs do not recommend, endorse, qualify, guarantee, or make any representations or warranties (express or implied) regarding the findings, services, work, quality, financial stability, or performance of Energy Solutions or any of Energy Solutions’ distributors, contractors, subcontractors, installers of products, or any product brand listed on Energy Solutions’ website or provided, directly or indirectly, by Energy Solutions. If applicable, prior to entering into any Terms of Use, customers should thoroughly review the terms and conditions of such Terms of Use so they are fully informed of their rights and obligations under the Terms of Use, and should perform their own research and due diligence, and obtain multiple bids or quotes when seeking a contractor to perform work of any type.

Executive Summary

The Wastewater Energy Transfer (WET) Market Study CalNEXT project explored WET market potential in California investor-owned utility territory and assessed how WET can reduce the barriers to energy efficiency and electrification. The project aimed to achieve this by decreasing energy consumption and demand, decreasing operating costs, and increasing building energy resiliency across nonresidential (commercial, industrial, and agricultural) customer segments. This project assessed WET technologies and their relevance to the California nonresidential buildings market to better understand the landscape and program impacts and how to scale the market for nonresidential WET systems.

WET technology leverages the heat energy in wastewater for useful purposes. Sanitary wastewater is typically at least ambient room temperature and can serve as a heat sink or heat source. WET systems use heat exchangers and/or heat pumps to enhance efficiency of cooling systems by rejecting heat from building systems to wastewater, and reducing load on cooling towers and other heat rejection equipment to enhance efficiency of cooling systems. WET systems also recover heat from wastewater to preheat water or other fluids for water heating, space heating, or process loads.

This market assessment investigated WET adoption, technology penetration, and energy savings potential using a literature review, stakeholder surveys, interviews, and site visits. Based on the findings, the project team calculated energy savings for space cooling, space heating, and domestic hot water heating end uses at the building level for the two most promising applications for WET in California: office and multifamily housing.

Site visits conducted September 2025 through October 2025 further characterized the market and increased the accuracy of the California investor-owned utilities WET market energy savings potential estimate. The site visits explored the feasibility of WET systems in four commercial and industrial buildings within three California climate zones, the results of which we used to uncover solutions for barriers to WET system installations in California investor-owned utilities territory.

A summary of WET measure descriptions and market assessment findings is provided in this report's [Market Assessment Recommendations](#) section and in the [Conclusions](#) section. The research team recommends further study of WET technology integrated with chillers and cooling towers via a field demonstration at a commercial or industrial customer site in California investor-owned utilities territory.

Key findings from each instrument include a detailed literature review, surveys, interviews, and data collected during site visits.

Literature Review

The project team’s literature review assessed 14 case studies and dozens of trade journal articles, industry publications, and conference proceedings to understand existing heat recovery technologies, off-the-shelf technology currently available, the latest vendor offerings in the market, and insights on WET infrastructure and energy savings potential of WET for nonresidential building systems. Findings include demographics of building owners and managers in California to help the investor-owned utility energy efficiency programs understand the commercial, industrial, and agricultural buildings market, which will allow them to gain insights into energy efficiency opportunities in these sectors.

- There are 24,000 commercial buildings totaling 12 billion square feet across every county in California, comprising 80 percent of the nonresidential buildings in the state.
- Large (buildings 100,000 square feet or greater in size) office and multifamily housing buildings present the largest market for WET system applications due to consistent wastewater flow rates and demand for space cooling, space heating, and domestic hot water heating.
- The California Energy Code (Title 24, Part 6) does not require nonresidential buildings to incorporate heat recovery or heat rejection via WET.
- Manufacturer A is developing the most projects in North America; there are not yet any WET projects in California.
- The ideal sectors and building types for WET technology are large commercial and industrial (multifamily housing, office, public assembly, lodging, K-12 school, college/university), wastewater treatment plants, manufacturing facilities, and district energy systems and thermal energy networks. The buildings in California investor-owned utilities territory with the greatest potential for WET are large office, large multifamily buildings, and the 100-plus wastewater treatment plants in the Los Angeles, San Diego, and San Francisco regions.
- Integration with wastewater treatment infrastructure, such as sewer lines, and heat pump systems—like ground-source (geothermal) heat pumps—enhance the benefits of WET technology for energy savings, demand reduction, and heating load reduction in target nonresidential WET markets.
- Energy savings for WET space cooling applications for large office and multifamily housing buildings in investor-owned utilities territory are estimated to provide 13 percent to 16 percent electricity savings when replacing chillers.

Surveys

Building owners and facility managers across California shared information about their baseline power distribution systems and level of interest in energy efficiency and electrification projects with the team, further informing our understanding of the California nonresidential buildings market’s adoption of WET systems and barriers to efficiency.

Key findings from the survey responses are summarized below.

WET Adoption

- Baseline technology characterization is recommended to continue into the site visits phase of this project.

- Most respondents use electric water-cooled chillers, which aligns with the value proposition for WET eliminating cooling towers in commercial and industrial buildings.
- Commercial and industrial buildings in California investor-owned utilities territory with electric water-cooled chillers show interest in learning more about WET system benefits.
- More data from representative facilities—such as large office and industrial buildings—is necessary to confirm the chilled water baseline for WET incentive program design.
- Most respondents were not aware of WET system benefits, and some were not interested in the adoption of WET systems at their facilities, which emphasizes the need for customer education and vendor workforce development.

Barriers to Energy Efficiency

- Low awareness of WET system types and applications, as well as limited knowledge of WET system benefits for California commercial and industrial buildings, will be a barrier for any pilot program.
- Smaller buildings, those without a consistent source of wastewater flow (either from a nearby sewer line or from building-level end uses), and sites with large fluctuations in wastewater flow are less suitable for WET applications.
- First costs for materials and labor are the primary barrier to respondents' energy efficiency project installations, which highlights the need for WET incentive programs to offset costs.
- One- to two-year payback periods are preferred by the majority of survey respondents, which may be challenging to achieve with WET projects—unless significant incentives are offered for projects.

Interviews

Industry experts and stakeholders across key commercial building market segments provided feedback in 2025. Refer to the [Interview Findings](#) section of this report to understand the level of WET adoption across nonresidential buildings in California, insights on energy savings potential of WET systems, and industry perspectives about baselines, industry standard practice, and the status of standards, energy codes, and third-party certification programs affecting nonresidential buildings.

Key findings from interviews are summarized below.

Energy Code

- Requirements for heat recovery or heat transfer with wastewater are not being considered for the 2028 California Energy Code (Title 24).

WET System Design

- District energy systems connected to wastewater treatment plants are niche applications for WET that provide sufficient wastewater flows for significant savings at multiple commercial and industrial buildings.
- Wastewater flows can fluctuate considerably and central plants serving thermal energy networks must account for the low depth of wastewater in sewer lines.

WET System Adoption

- There were no WET systems in operation or installed in California buildings in 2025.

- A WET system is under consideration for a San Francisco Bay Area airport retrofit project with an on-site wastewater treatment plant.

Site Visits

The team visited four commercial and industrial buildings in 2025 to observe building systems, such as wastewater infrastructure, space cooling, space heating, and water heating equipment. These facilities ranged from 150,000 square feet to 350,000 square feet, with an average size of 257,500 square feet.

Key findings from the site visits are summarized below.

Baseline Wastewater Systems

- The four sites visited do not use wastewater heat recovery technology to reduce energy use from space cooling, space heating, or domestic hot water heating systems.
- Two of the sites visited self-manage building wastewater, and two of the sites visited pipe wastewater to municipal sewer lines.

Barriers for Efficiency

- Two of the four buildings did not have easy access to building-level wastewater infrastructure.
- One of the four buildings did not have space in existing mechanical rooms for WET heat exchanger equipment.
- Sewer-line level WET systems would be challenging to integrate with WET heat recovery equipment at one of the four sites, due to the distance between the buildings and the wastewater treatment pond.
- Older HVAC systems would present additional project costs for a WET retrofit at one of the four sites.

Opportunities for WET Adoption

- The team observed chillers and cooling towers at each of the four visited sites, where WET heat exchangers could feasibly connect to cooling systems to reduce electricity consumption by using on-site wastewater sources as a heat sink.
- One of the four visited sites could use WET to reduce loads on cooling towers that cool effluent from industrial processes before piping to wastewater treatment systems.
- The heat recovered from effluent by WET heat exchangers can serve hot water supply and pre-heat water used for industrial processes at one of the visited sites.

Glossary of Terms

Commercial building: A structure dedicated entirely to trade, commerce, and professional activities.

District energy: Thermal energy networks that connect multiple buildings to one or more central plants that produce hot water, steam, or chilled water.

Industrial building: A structure that is primarily for industrial activity, generally not open to the public, including but not limited to warehouses, factories, and storage facilities.

Multifamily building: A type of commercial building, like a multi-dwelling unit, that has multiple separate housing units for residential use.

Thermal energy network: A system of interconnected hydronic piping that transfers heat in and out of multiple buildings.

Abbreviations and Acronyms

Acronym	Meaning
ASHP	Air-source heat pump
Btu	British thermal unit
CBRE	Coldwell Banker Richard Ellis
CEA	Controlled environment agriculture
CEC	California Energy Commission
C&I	Commercial and industrial
CEUS	Commercial End-Use Survey
CIP	Clean in place
COP	Coefficient of performance
CUP	Central utility plant
CZ	Climate Zone
C&I	Commercial and industrial
DHWH	Domestic hot water heating
EE	Energy efficiency
EUI	Energy use intensity
GHG	Greenhouse gas
GJ	Gigajoule
GPD	Gallons per day
HVAC	Heating, ventilation, and air conditioning
IOU	Investor-owned utility
kBtu	Kilo-British thermal units

Acronym	Meaning
kW	Kilowatt
kWh	Kilowatt-hour
MBtuh	Thousand British thermal unit per hour
MMBtu	Million British thermal units
MW	Megawatt
NEU	Neighborhood Energy Utility
PG&E	Pacific Gas & Electric
Q	Quarter
SCE	Southern California Edison
SDG&E	San Diego Gas & Electric
TEN	Thermal Energy Network
US DOE	United States Department of Energy
WET	Wastewater energy transfer
WWTP	Wastewater treatment plant

Contents

Acknowledgements.....	i
Executive Summary	ii
Literature Review.....	iii
Surveys	iii
Interviews.....	iv
Site Visits.....	v
Glossary of Terms.....	vi
Abbreviations and Acronyms	vii
Introduction.....	11
Market Overview	11
Background	18
Nonresidential Facility Energy Consumption.....	20
Emerging Technology Overview	21
Market Assessment.....	23
WET Applications	28
Product Overview.....	34
Case Studies	35
Research Objectives.....	35
US Case Studies	38
International Case Studies	46
WET Benefits.....	56
Energy Savings.....	57
Market Assessment Objectives.....	59
Customer Surveys.....	59
Stakeholder Interviews	59
Customer Site Visits	59
Market Assessment Methodology and Approach.....	60
Market Assessment Results	61
Survey Results	61
Interview Findings.....	62
Site Visit Results.....	64
Recommendations	66
Measure Descriptions	66
Market Assessment Findings	67
Conclusions.....	69
Appendix A: Survey Questionnaire.....	70
Appendix B: Site Visit Reports	73
Site Visit Report #1: Hospital A	73
Site Visit Report #2: Hospital B	74
Site Visit Report #3: Food Processing Facility A.....	75
Site Visit Report #4: Commercial Office A	76
References	78

Tables

Table 1: California nonresidential building area by sector.....	11
Table 2: Bay Area rentable industrial building area.	15
Table 3: Central Valley rentable industrial building area.	16
Table 4: Southern California rentable industrial building area.....	17
Table 5: Baseline chiller system costs, 2025.	24
Table 6: Baseline boiler system costs, 2025.....	25
Table 7: Baseline chiller system costs, 2025.	26
Table 8: California Energy Code requirements affecting nonresidential building systems.....	35
Table 9: WET non-energy benefits.	56
Table 10: Annual facility-level electric WET savings potential.	58
Table 11: Facility-level natural gas WET savings potential.....	58
Table 12: Stakeholder engagement summary.....	60
Table 13: Interview summary.....	62
Table 14: Site visit summary.....	64
Table 15: WET measure descriptions.....	66

Figures

Figure 1: California statewide commercial building square footage by type.	12
Figure 2: California commercial building square footage by year.....	13
Figure 3: Rentable California industrial building area, Q1 2025.....	14
Figure 4: Rentable Bay Area Warehouse and Manufacturing Building Area, Q1 2025.	16
Figure 5: California greenhouse square footage by crop type.	18
Figure 6: California commercial building electricity usage by type.....	20
Figure 7: Wastewater energy heat recovery process.....	21
Figure 8: Heat recovery from wastewater.	22
Figure 9: United States thermal energy network legislation status, 2025.	32
Figure 10: District energy system.	33
Figure 11: Amalgamated Housing Cooperative Towers WET retrofit.....	39
Figure 12: WET infrastructure for Alafia design.	40
Figure 13: WET infrastructure at D.C. Water Administrative Building.	41
Figure 14: WET system schematics for D.C. Water Administrative Building.....	42
Figure 15: Aboveground effluent pipe.	43
Figure 16: National Western Center district energy system.....	44
Figure 17: WET infrastructure for Gateway Theatre.	48
Figure 18: WET Infrastructure for Regional Water Resource Centre.....	49
Figure 19: WET Infrastructure for Regional Water Resource Centre.....	50
Figure 20: WET infrastructure for False Creek Energy Centre.	52
Figure 21: WET Infrastructure for seven35.....	53
Figure 22: Hot tapping sewer main.	54
Figure 23: Hospital and wastewater pond.	73
Figure 24: Hospital B sanitary pipe and tank.....	74
Figure 25: Cooling tower area for Food Processing Facility A.	75
Figure 26: One of four sewer risers in Commercial Office Building A parking garage.....	76

Introduction

The following sections offer a comprehensive analysis of the 2025 California nonresidential building markets, encompassing commercial, industrial, and agricultural sectors. This analysis is used for calculating the wastewater energy transfer (WET) energy savings market potential for different commercial and industrial (C&I) sectors in investor-owned utilities (IOU) territory.

This technology area aligns with the Integrated Systems Technology Family of the 2024 edition of the CalNEXT Whole Buildings Technology Priority Map (TPM). Systems like WET connected to heat pumps—which serve space cooling and heating, domestic hot water (DHW), and process heating end uses—are emerging technologies that can enable improved efficiency and the decarbonization of buildings and improve the cost-effectiveness of efficiency and electrification projects in new and existing buildings.

Market Overview

The size and age of California’s commercial, industrial, and agricultural building stock are described in the sections below to evaluate the segments of the state’s nonresidential buildings that present the greatest potential applications for WET, which will offer energy savings in space cooling, space heating, and hot water heating applications.

Existing buildings comprise the majority of California’s commercial building stock; 93 percent of California buildings were built before 2000 (NREL 2021). While there is market potential for new energy recovery technologies installed to serve new construction projects, given the scale of historic California commercial building stock, retrofits of older existing buildings represent a larger market opportunity for the integration of WET systems to enhance efficiency and resiliency.

The results of the building industry analysis for each of the three sectors are summarized in Table 1. The building area is quantified in millions of square feet (sq ft), with commercial buildings comprising 80 percent of the total nonresidential building area in California. The combined categories of large and small offices make up the largest sector within nonresidential buildings—2.09 billion sq ft and present the greatest opportunity for WET systems.

Table 1: California nonresidential building area by sector.

Buildings Industry Sector	Building Area (million ft²)
Commercial	12,000
Industrial	2,640
Agricultural (Indoor Agriculture)	313
Statewide Total	14,953

Table Data Source: ERI 2025.

Commercial Buildings

The United States Department of Energy (US DOE) defines commercial buildings as buildings that are not considered a residential building (U.S. DOE n.d.). Energy consumed by commercial buildings generates significant greenhouse gas (GHG) emissions, contributing to 16 percent of GHG emissions in the United States (Steven Winters Associates 2023). In California, the commercial real estate sector has witnessed substantial growth, with commercial floorspace expanding by 21 percent since 2006; this growth can most likely be attributed to the recovery from the 2007 global financial crisis.

In 2022, the total combined area of commercial spaces in the state was estimated to be over 12 billion sq ft, spread across over 24,000 individual facilities according to the California Commercial End-Use Survey. Figure 1 below describes the footprint of California commercial buildings in percentage of total statewide commercial building area, breaking down the distribution of floor space across commercial building types. The combined categories of large and small office make up the largest area (2.09 billion sq ft).

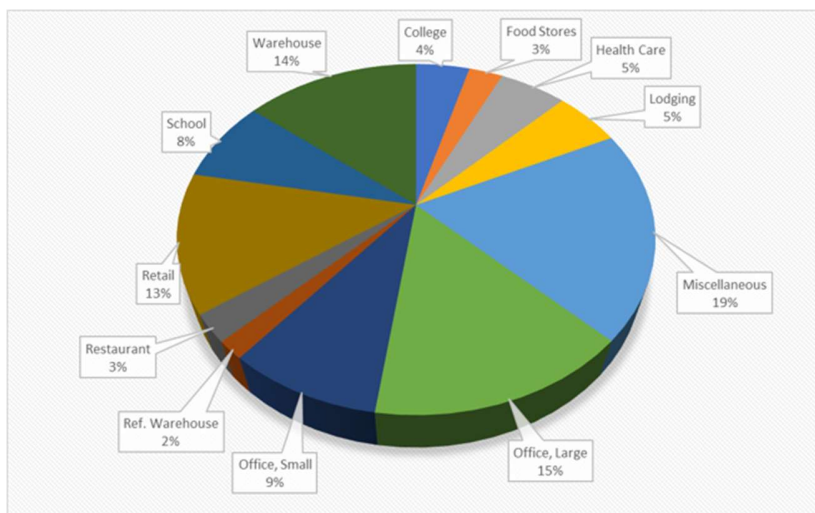

Figure 1: California statewide commercial building square footage by type, 2022.

Figure data source: CEC 2024.

The largest individual category of commercial floor stock is miscellaneous commercial buildings—including buildings like auto repair shops, amusement parks, prisons, and dry cleaners—which make up the largest area (1.7 billion sq ft). Other categories with large floor stock include large office (1.32 billion sq ft), warehouse (1.39 billion sq ft), and retail (1.12 billion sq ft) (Ibid.).

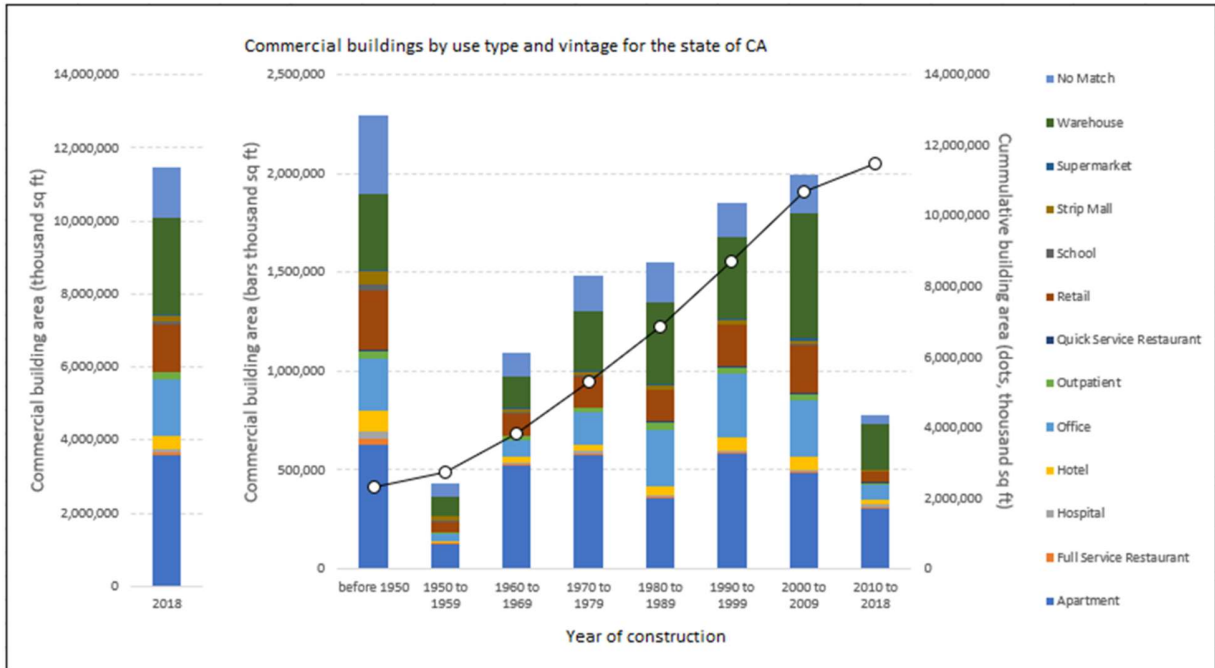

Figure 2: California commercial building square footage by year.

Figure data source: NREL 2021.

Most of California’s building stock are existing buildings; only 7 percent of California’s commercial buildings were built within the past 20 years. Figure 2 illustrates the distribution of California commercial building stock across use type and vintage for different ten-year periods using data from 2018. There were 11.48 billion square feet of commercial buildings in California in 2018 (NREL 2021).

Growth in commercial building inventory was slow between 2010 and 2018 and can be attributed to several factors, including stringent building codes and zoning regulations, rising construction costs, limited land availability, economic downturns such as the global financial crisis of 2007, and a preference for renovating existing structures. These challenges made new construction projects more time-consuming and expensive, leading to a slower rate of new commercial building development in California.

Industrial Buildings

Coldwell Banker Richard Ellis (CBRE) examined California’s industrial building stock separated by region in the first quarter of 2025. Industrial markets are typically surveyed by region due to variations in economic conditions, infrastructure, natural resources, and regulatory environments. These nuances impact industrial demand, investment patterns, and logistics, which makes it less relevant to characterize the industrial market of the state of California as a whole. The following section describes the California industrial buildings sector by region using data from three major metropolitan areas: the Bay Area, Central Valley, and Southern California (CBRE 2025). The industrial inventory of California is only analyzed for regions where data is readily available and publicly accessible; it can be assumed that most of the industrial activity in California occurs in these three regional areas.

Across the three major California metropolitan regions sampled, there are 2.64 billion sq ft of rentable industrial buildings. Figure 3 shows the distribution of industrial buildings by region. The Southern California region of California has the largest industrial building stock of the three regions, with 1.8 billion sq ft of rentable industrial buildings. The Bay Area region has the least industrial building area of the three California metropolitan regions studied with 389 million sq ft of rentable industrial building area but has a similar sized industrial building stock to the Central Valley (447 million sq ft).

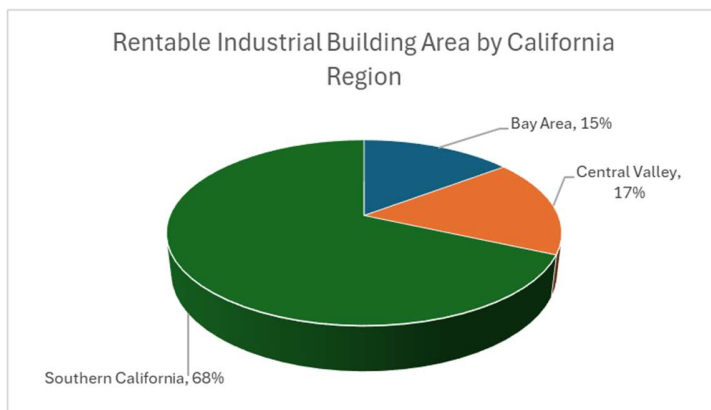

Figure 3: Rentable California industrial building area, Q1 2025

Figure data source: CBRE 2025.

The following sections explore these three regions in greater detail and uncover that Oakland, Sacramento, and Los Angeles County are the California metropolitan areas with the largest industrial building stock with potential for WET system applications.

BAY AREA REGION

The California Bay Area region includes six metropolitan areas, with Table 2 showing the distribution of the 389 million sq ft of rentable industrial building stock across those areas. Oakland is the region with the greatest concentration of industrial buildings. The proportion of warehouse and manufacturing sq ft in this region is displayed in Figure 4; this data is not available for the other regions.

Table 2: Bay Area rentable industrial building area.

Bay Area Metropolitan Area	Rentable Industrial Building Area (sq ft)
San Francisco	21,965,419
SF Peninsula	34,231,921
Silicon Valley	110,700,518
Oakland	127,107,625
I-680 Corridor	38,296,020
Napa/Solano	56,359,537
Total Bay Area Rentable Industrial Building Area	388,661,040

Table data source: Ibid.

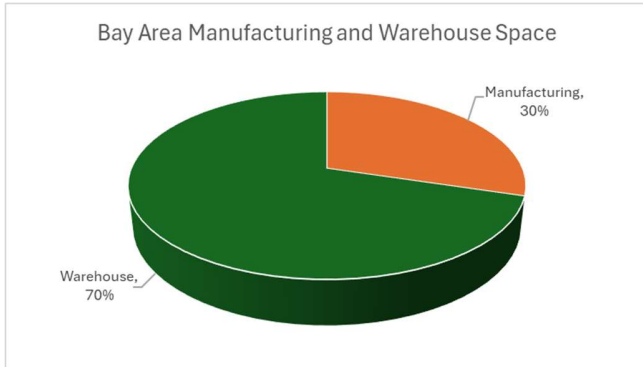

Figure 4: Rentable Bay Area Warehouse and Manufacturing Building Area, Q1 2025

Figure data source: Ibid.

CENTRAL VALLEY REGION

The Central Valley region of California is comprised of three market sectors with an industrial building area totaling 447 million sq ft. The market sector is comprised of buildings with 10,000 sq ft or larger. Sacramento is the metropolitan area with the greatest concentration of industrial buildings in the Central Valley region. Table 3 shows the rentable industrial building area in each of the three metropolitan areas in California’s Central Valley.

Table 3: Central Valley rentable industrial building area.

Central Valley Metropolitan Area	Rentable Industrial Building Area (sq ft)
South Central Valley	109,959,864
Central Valley	142,527,980
Sacramento	194,771,368
Total Central Valley Rentable Industrial Building Area	447,259,212

Table data source: Ibid.

SOUTHERN CALIFORNIA REGION

The Southern California region of California is comprised of five metropolitan areas with industrial buildings totaling 1.8 billion sq ft. Los Angeles County has the greatest concentration of industrial buildings in the Southern California region. Table 4 shows the rentable industrial building area in the Southern California region.

Table 4: Southern California rentable industrial building area.

Southern California Metropolitan Area	Rentable Industrial Building Area (sq ft)
Los Angeles County	882,813,037
Ventura County	67,783,314
Inland Empire West	354,763,781
Inland Empire East	310,185,059
San Diego	188,120,866
Total Southern California Rentable Industrial Building Area	1,803,666,057

Table data source: Ibid.

Agricultural Buildings

This section summarizes a segment of the agricultural market using enclosed buildings for crop production that could feasibly use WET systems: greenhouses and indoor farms.

Greenhouses and indoor farms are a growing segment of the agricultural market involving crops grown in closed environments, characterized as controlled environment agriculture (CEA). The US Department of Agriculture defines CEA as production "under glass or other protection" (US Department of Agriculture 2024), while the California Energy Code categorizes CEA facilities into greenhouses, conditioned greenhouses, and indoor growing spaces (California Energy Code 2022). Greenhouses feature a skylight to-roof ratio of 50 percent or more; conditioned greenhouses have heating or cooling systems exceeding specific capacities.

More greenhouses and indoor farms are being built in California to meet the increasing demand for a consistent supply of high-quality horticultural products. In 2017, there were only 2,464 CEA operations active within the state of California (U.S. Department of Agriculture 2019), and in 2024, this number grew to 4,611 CEA operations (U.S. Department of Agriculture 2024).

Figure 5 describes the footprint of the California CEA industry in sq ft, and there are 313 million sq ft of greenhouses and indoor farms in California. 61 percent of every sq ft of CEA facility in California is for greenhouse floriculture or nursery crop production.

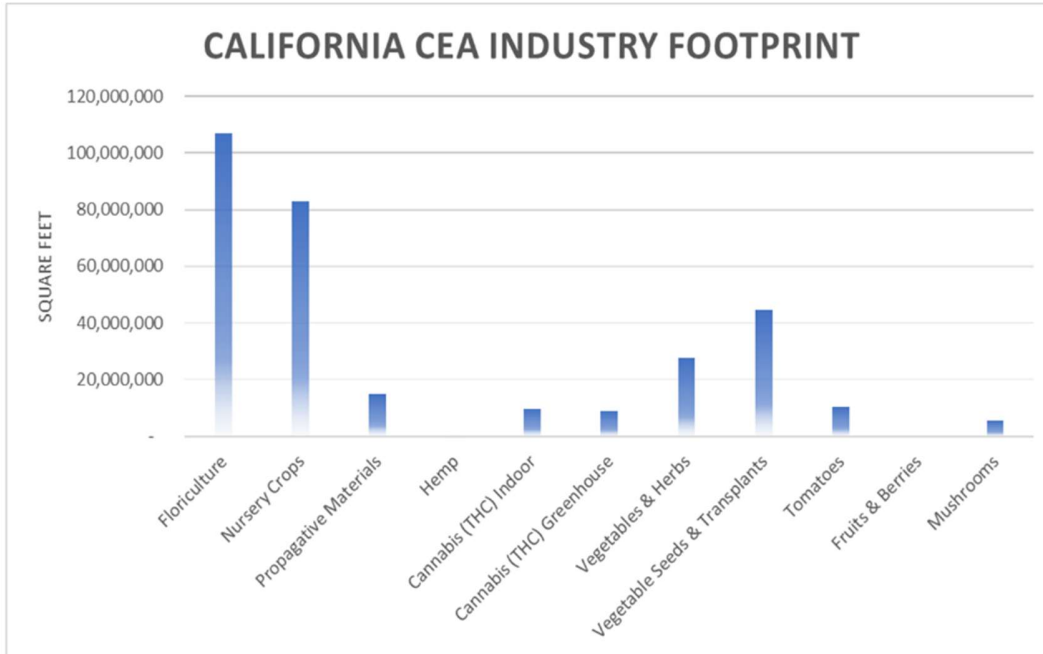

Figure 5: California greenhouse square footage by crop type.

Figure data source: USDA 2024; California DCC 2024.

CEA facilities are potential candidates for WET system application, as many greenhouses in California have year-round space heating and process water heating loads and could integrate WET heat exchangers into existing hydronic heating systems.

Background

This project investigated the energy and demand savings potential of WET systems, and also explored commercially available WET applications in use within commercial buildings and industrial facilities in California electric IOU service territory.

This market assessment and associated WET market characterization were guided by the following research questions:

1. What are the various WET technologies available and applicable to the California market?
2. What are the ideal sectors and building types for WET technology?
3. How can WET technology be optimized for energy savings, demand reduction, and/or heating load reduction in various C&I applications?

4. Are there unique implementation challenges associated with integrating WET technology into existing buildings in comparison to new construction?
5. What are the barriers and impacts for WET technology, specifically regarding the implementation of equipment, integration with end uses, tenant and customer space impacts, and maintenance?
6. How can the controls from the WET system be integrated into the building's existing network?

WET technology leverages the heat energy in wastewater for various applications, including space heating, domestic hot water heating (DHW), and space cooling. Sanitary wastewater is typically at ambient room temperature and can serve as a heat sink or heat sources; WET systems recover heat from wastewater to preheat water or other fluids for water heating, space heating, or process loads. WET systems can also enhance the efficiency of cooling systems by rejecting heat from building systems to wastewater heat exchangers, reducing load on cooling towers and other heat rejection equipment.

The following sections describe the energy consumed by C&I buildings, the components associated with a WET system, the major WET system types, and the energy saving potential of WET in several modes.

Nonresidential Facility Energy Consumption

Commercial office buildings are the primary consumers of electricity statewide. Understanding the dynamics of energy consumption within these diverse commercial spaces is essential for identifying the opportunities for efficient WET implementation with the greatest energy-saving potential. Figure 6 describes statewide commercial building electricity usage by building type (CEC 2024).

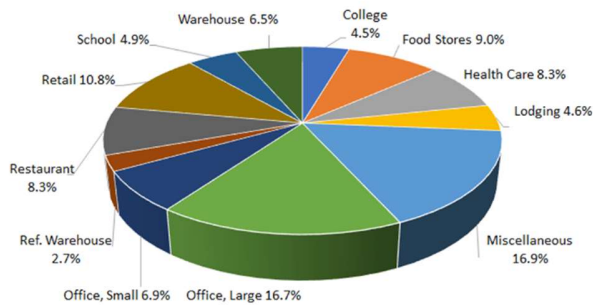

Figure 6: California commercial building electricity usage by type, 2022.

Figure data source: CEC 2024.

The greatest market potential for energy savings in commercial buildings is within the miscellaneous, large office, food stores, healthcare, and restaurants categories. “Miscellaneous” consumes the most electricity in California; this category includes various types of buildings, such as auto repair shops, dry cleaners, and amusement parks. The major systems driving electricity consumption at these types of buildings are lighting; heating, ventilation, and air conditioning (HVAC); and plug loads for specialty business equipment—for example, washers and dryers at laundromats, air compressors and power tools at auto repair shops, and concessions foodservice equipment at amusement parks.

“Large office” is the second-highest commercial consumer of electricity; major systems driving electricity consumption in this category are building-specific and can include lighting, HVAC, plug loads from computers and copiers, and breakroom equipment, and potentially electricity to drive elevators, data centers, and commercial kitchens (CEC 2024).

Food Stores, Health Care facilities, and Restaurants are other categories of commercial buildings driving statewide electricity consumption. Food Stores use electricity for refrigeration, lighting, and HVAC systems, as well as commercial kitchens like bakeries and delis, while Healthcare Facilities electricity consumption is driven by lighting, advanced HVAC systems, plug loads for medical equipment, and data centers for hospitals and larger medical office buildings. Restaurants use electricity predominantly for lighting, refrigeration, commercial kitchen appliances, and HVAC, including kitchen exhaust and makeup air systems (Energy Star n.d.).

Emerging Technology Overview

Although WET infrastructure can serve any electrical end use in all types of buildings, this study focused on applications for nonresidential buildings. WET systems use simple, proven technology to take advantage of a wasted source of energy suitable for heating and cooling buildings. There are over 500 installations worldwide—with the greatest number of operational WET systems in Canada, Switzerland, and Germany (more information is available in the International Case Studies section)—and some systems can offer over 20 years of operational data. One study found that WET systems could supply 3 percent of all German buildings with a 10-kilowatt (kW) to 20-megawatt (MW) wastewater heat source and/or heat sink (Schmid 2008).

The WET technologies available and applicable to the California market can be described as closed-loop heat exchangers with optional and customizable heat pump configurations, which buildings can use to provide space cooling and heating, as well as hot water heating. WET systems send wastewater through a heat exchanger to extract heat, similar to exhaust recovery ventilator systems, and can be connected to heat pumps to enhance system performance. Heat can then be moved actively with a heat pump or passively with heat exchangers (SHARC Energy 2025). Figure 7 below shows a WET unit in heating mode.

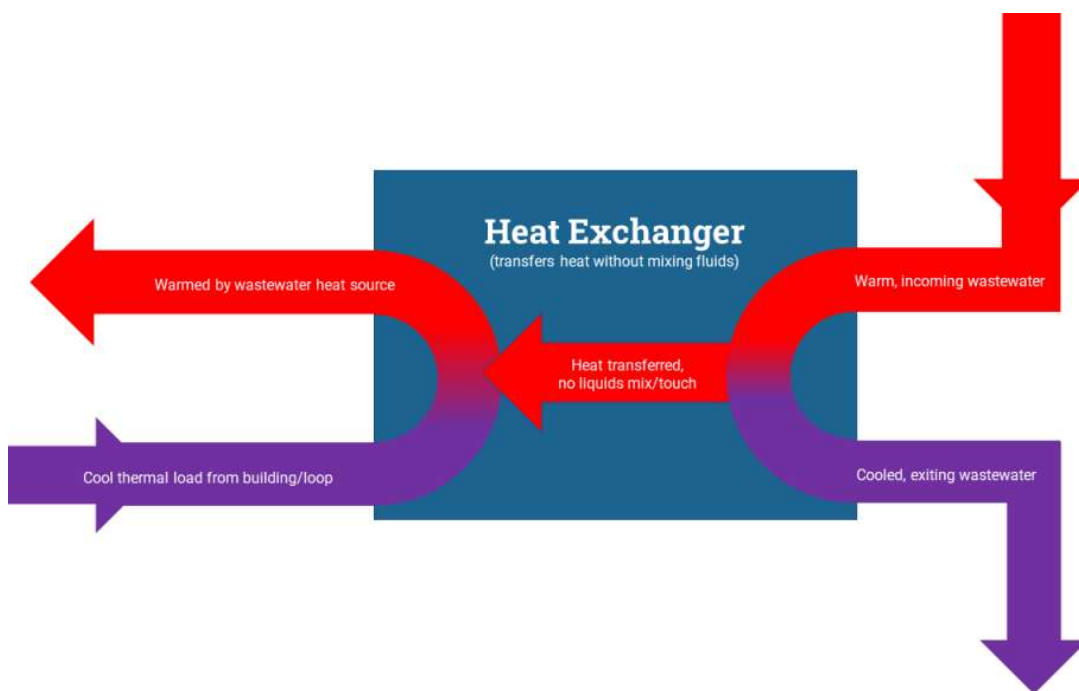

Figure 7: Wastewater energy heat recovery process.

Figure data source: WET Closed-Loop Heat Transfer. Image Source: SHARC Energy 2025.

Wastewater sources for WET systems can be found in many C&I buildings, including:

- Greywater from sinks, showers, dishwashing, and clothes washing equipment
- Blackwater from toilets
- Effluent from industrial process wastewater (pre-treatment)

- Effluent from wastewater treatment plants (post-treatment)

Wastewater heat recovery systems can serve as a heat source and/or a heat sink to:

- Preheat incoming domestic hot water
- Preheat space heating hot water and process water
- Receive heat rejected from chilled water return water flows for hydronic cooling systems (replacing cooling towers)
- Exchange heat with a district energy system

District energy systems use one or more central plants to make hot water, steam, and/or chilled water for a network of insulated pipes that provide hot water, space heating, and/or air conditioning for nearby buildings. District energy systems are demonstrated in downtown business districts, college and university campuses, hospitals and healthcare facilities, airports, military bases, and industrial complexes across the United States and in California. By combining loads for multiple buildings, district energy systems create economies of scale that help reduce energy costs and enable the use of energy efficiency technologies like WET (U.S. Department of Energy 2020)—for example, Cordia’s San Diego 9,340-ton cooling district is located in IOU service territory and serves 3.2 million sq ft of commercial buildings (Cordia 2025).

Heat can be recovered using WET heat exchangers placed at the component, building, sewer, or wastewater treatment plant (WWTP) level, as shown in Figure 8.

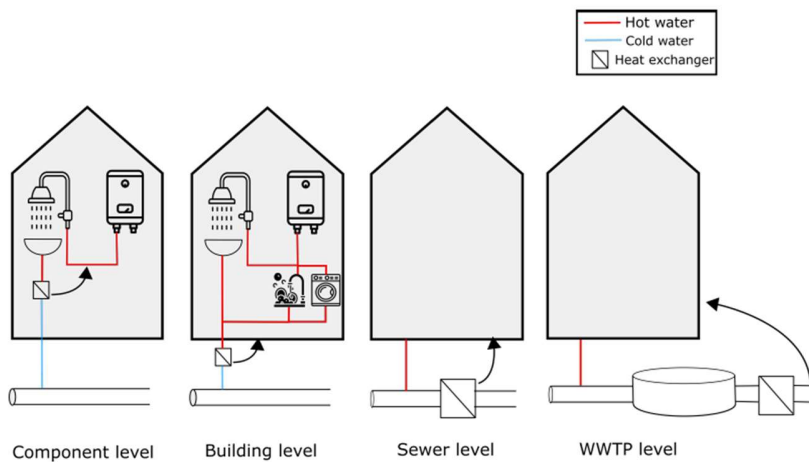

Figure 8: Heat recovery from wastewater.

Figure data source: Nagpal et al 2021.

WET systems can allow commercial facility operators to reduce energy consumption for hydronic heating and cooling systems by up to 50 percent, with minimal additional infrastructure required and minimal interference to existing waste systems (U.S. DOE 2024). This technology not only reduces building energy consumption, but also reduces strain on centralized power systems, improving overall grid reliability.

Market Assessment

WET systems present an opportunity to replace baseline space heating, space cooling, DHWH, and process hot water heating systems in a variety of commercial, industrial, and agricultural facilities.

Baseline Systems

The versatility of WET systems allows for integration into a variety of applications in non-residential buildings. WET systems must be connected to a cooling or heating stream that uses the waste as a sink or source, like a space heating and cooling system or a hot water heating system. The following sections outline the typical (baseline) types of mechanical systems suitable for WET integration; in some cases, WET systems may replace baseline systems entirely.

SPACE COOLING: CHILLERS WITH COOLING TOWERS

Many non-residential buildings use air- and water-cooled chillers to cool water for a variety of purposes, including space and process cooling. Commercial facilities and campus settings frequently use chilled water for space cooling, while industrial applications use it for cooling processes. Chillers leverage a refrigeration cycle to pull heat from a chilled water loop, which must be rejected through condensers. Though air-cooled condensers may be used for smaller chillers, medium and larger chillers commonly used in large commercial buildings are typically water-cooled; heat is rejected from the chiller to a condenser water loop and then must be rejected from the condenser water loop, typically using cooling towers.

In a cooling tower, condenser water is sprayed over a “fill media” in the cooling tower, which is then cooled and partially evaporated with the help of a fan. The evaporative cooling effect increases the heat rejection capacity and efficiency of cooling towers compared to alternative technologies, but can also lead to significant water losses. The US Environmental Protection Agency (EPA) estimates that the average cooling tower evaporates approximately 1.8 gallons of water for every ton-hour of cooling (US EPA 2017). Other ways cooling towers can waste water: blowdown (used to clean chiller water to avoid solids entering the heat exchanger on the chiller system) and drift (small water droplets being carried away by the air blown from the fan, which can result in 5 percent to 20 percent water loss). While more water-efficient alternative technologies do exist, such as closed-circuit and dry cooling towers, these options are typically less energy efficient and lower capacity than cooling towers at a given footprint, due to the lack of evaporative cooling.

[Table 5](#) summarizes cost data gathered from RSMears for scroll and centrifugal chillers, as well as cost data from Briggs Equipment Sales for Daikin-manufactured cooling towers of various sizes that are typical for C&I applications (Briggs Equipment Sales 2025).

Table 5: Baseline chiller system costs, 2025.

System Capacity (tons)	Scroll Chiller Cost (\$)	Centrifugal Chiller Cost (\$)	Cooling Tower Cost (\$)
50	\$25,000	--	\$18,000
125	\$62,500	--	\$29,000
250	\$125,000	\$87,500	\$55,000
500	--	\$175,000	\$95,000
1000	--	\$350,000	\$175,000

Table data source: RSMMeans, Briggs Equipment Sales, 2025.

HOT WATER HEATING AND SPACE HEATING: BOILER SYSTEMS

Many C&I buildings use boiler systems to create hot water or steam, which is used for various heating applications, including water heating, space heating, DHWH, and process heating. While boiler systems can vary in size, design, and efficiency, all boilers burn fuel to heat water, creating either hot water or steam for the applications described above. Natural gas is the most common boiler fuel in California IOU territories served by Pacific Gas & Electric (PG&E), Southern California Edison (SCE), and San Diego Gas & Electric (SDG&E), though alternative fuels like propane, fuel oil #2, and wood pellets are common outside of IOU territory, or as backup fuel. The efficiencies of these systems can range from 80 percent or lower for traditional steam boilers, and up to 98.5 percent for condensing boilers (US DOE 2025). Electric boilers using resistance heating elements are uncommon due to their large size compared to fuel-burning boilers of equivalent capacity.

Boiler systems frequently lose water due to leaks, blowdown, evaporation, and various other reasons, and therefore require makeup water anywhere from 2 percent to 10 percent of the volume. Since the water that comes into the system is typically around the local groundwater temperature (58°F to 68°F for much of California), this can be a major loss of heat for the overall system.

Table 6 summarizes RSMMeans cost data for standard efficiency and high-efficiency boilers of various sizes that are typical for C&I applications. There is no generic boiler size used for a C&I building, as there are many factors that affect the design heating load for a property, such as age, distribution, sq ft, and fuel sources; a common rule of thumb is between 20 British thermal units (Btu) to 50 Btu per sq ft.

Table 6: Baseline boiler system costs, 2025.

System Capacity (kilo British thermal unit (kBTU)/hr)	Standard Efficiency Boiler Cost (\$)	High Efficiency Boiler Cost (\$)
750	\$26,000	\$30,000
1000	\$32,000	\$34,000
1500	\$43,000	\$50,000
2000	\$52,000	\$55,000
3000	\$61,000	\$81,000

Table data source: RSMMeans, 2025.

SPACE COOLING AND SPACE HEATING: HEAT PUMPS

Instead of boilers and chillers, some C&I buildings use heat pumps for both space heating and cooling. Heat pump systems are equipped with a switching valve, which allows the system to reverse the order of the refrigeration cycle. In cooling mode, it works as a typical air conditioning system: heat is pulled from a conditioned space through the system’s evaporator and moved via a refrigerant to the condenser where the heat is rejected outside of the conditioned space. In heating mode, a heat pump can pull heat from outside and reject it into the conditioned space.

Since heat pumps are not burning fuel to create heat, but rather moving heat from one place to another, they can be highly efficient in space heating applications. For every unit of electricity consumed by a typical heat pump system, the system can provide three to five units of energy as heat to the space being conditioned. However, this principle also leads to one of the drawbacks of heat pumps: They become less efficient when nearing the limits of the design conditions.

When outdoor temperatures drop, more heat is needed in a conditioned space, but there is less heat for a heat pump to pull from outside to move inside. The same is true in reverse—when it is hot outside, more heat needs to be moved out of a conditioned space, but the heat pump is less easily able to reject heat from its condenser. While modern heat pumps and refrigerants have helped to mitigate this challenge, it can still be an issue with heating in extremely cold climates. A notable solution to this problem is the introduction of geothermal heat pumps connected to borefields, which keep a constant temperature source during extreme cold and warm events. This ensures the heat pump operates in their ideal window to reduce energy consumption and meet the space needs. The use of a geothermal system requires the installation of a well or horizontal piping loop, which increases the cost significantly over air-source heat pumps (ASHP).

With the increased adoption of heat pumps for space cooling and heating for C&I application, geothermal wells are a way to improve the year-round efficiency. Heat pumps vary in their energy coefficient of performance (COP) based on their heat sink, depending on cooling or heating operation. For example, a heat pump operating in heating mode will have an approximate COP of 3.0

when the outside environment is 40 °F, with the COP getting lower as the outside air temperature drops. With the addition of a borefield, the heat sink will remain at a constant ground temperature around 55 °F, which will stabilize the performance of the heat pump during its operation and reduce the energy consumption during both heating and cooling modes of operation.

The main barrier to geothermal for heat pumps is implementation costs, with drilling and installing a vertical or horizontal well accounting for about 50 percent of project costs. Additionally, there are many factors to consider, such as environmental impacts, geological location for the well, water flows across the well location(s), and integration into an existing or new heat pump—all factors that can significantly impact costs.

Table 7 summarizes cost data gathered from the US Energy Information Administration (EIA) for standard efficiency and heat pumps (U.S. EIA 2023). Geothermal heat pump and borefield cost data is site-specific and can range widely based on location, so the costs provided below are estimated based on industry experience.

Table 7: Baseline chiller system costs, 2025.

System Capacity (kBTU/hr)	Standard ASHP System Cost (\$)	High Efficiency ASHP System Cost (\$)	Ground-Source Heat Pump System Cost (\$)
36	\$5,940	\$7,560	\$30,000
60	\$9,900	\$12,600	\$40,000
96	\$15,840	\$20,160	\$45,000
120	\$19,800	\$25,200	\$60,000
240	\$39,600	\$50,400	\$100,000

Table data source: US EIA, 2023.

HEAT RECOVERY

Heat recovery systems—which are used to capture heat that would otherwise be wasted—have been in use for 100 years for process and industrial applications but are still relatively uncommon for space conditioning applications. An example of a heat recovery system is when the exhaust from a boiler is used to preheat incoming makeup and/or return water using a device called an economizer, which in turn will reduce the fuel load on the boiler, as the water will be at a higher temperature. Heat recovery ventilators transfer heat between exhaust air and incoming outdoor ventilation air without mixing the air streams, reducing the heating load for spaces with high ventilation requirements. Heat recovery chillers capture wasted heat generated during the cooling process that can then be leveraged for space or water heating applications.

The use of heat recovery in C&I applications is most commonly found through combined heat and power (CHP) systems, where electrical energy is generated and the waste heat stream from the engine or exhaust are used to serve various loads, including heating hot water for space heating, domestic hot water, or process loads for other industrial applications. Other heat sources that are applicable for heat recovery are data centers, process equipment, recapturing heat during pasteurization, or clean-in-place (CIP).

One of the major hurdles to implementing a heat recovery system is identifying the need for the captured waste heat near the source. If an application for the heat is not always required, a thermal energy storage system can be installed to schedule the use later when required. The cost for implementing a custom heat recovery system varies significantly based on the temperature differential, flow rate, and material for the piping or heat exchanger. A location for the equipment in space-contained areas can also play a role in heat recovery when implemented as a retrofit compared to a new construction.

WET Applications

The ideal sectors and building types for WET technology within the C&I markets are explored in the following sections to determine if certain sectors can achieve more cost-effective projects that will potentially have less barriers to installations.

C&I Buildings

C&I projects with consistent demand for space cooling, space heating, and DHWH are a good fit for WET at the building level, as shown in Figure 7.

Buildings that generate their own wastewater at a sufficient rate or have a sewer line adjacent to the building are better candidates for WET compared to buildings without reliable sources of wastewater on-site or nearby.

The following building types have been identified as priority candidates for WET applications (large buildings are defined as buildings greater than 100,000 square feet in size):

- Large multifamily
- Large office
- Large public assembly
- Large lodging
- Large K-12 school
- Large college/university
- Manufacturing
- Agriculture (greenhouses)
- Wastewater treatment plants

District energy commercial building candidates for WET applications at the building level are large multifamily, large office, public assembly, healthcare, and mixed-use buildings, as demonstrated in both US and international case studies (see Table 8). Wastewater production rates for large office buildings are around 5,500 gallons per day (GPD).

A distinct commercial candidate for WET is the large lodging buildings category, which includes multifamily housing facilities that produce wastewater at almost 19,000 GPD, such as apartments, student housing, senior living, and community housing. These applications are suitable for WET because of the consistent wastewater load from sinks, showers, and toilets, matched with a consistent demand for heating and cooling. Demonstrated multifamily applications showcase building-level WET systems that do not need to connect to sewer lines.

Industrial facilities that release effluent into the atmosphere or bodies of water are also good candidates for WET; examples include commercial food production facilities, pulp and paper mills, and textile production operations. Wastewater production rates for industrial effluent are extremely dependent on the product being manufactured.

Wastewater treatment plants (WWTPs) are another unique commercial application for WET, but these systems are often coupled with district energy infrastructure, which can make projects more complex and lead to longer timelines. IOUs may find district energy WET systems connected to

WWTPs to be challenging for incentive program implementation due to complexity, scale, and size of project for implementation.

More details about each project can be found in the [Case Studies](#) section of this report.

NEW CONSTRUCTION

WET has advantages in new construction applications because the integration of WET systems with heat pump systems and district energy infrastructure can be easier than in retrofit projects.

Read more about new construction WET system projects in the following case studies:

- [Brooklyn, New York](#) mixed-use campus
- [Washington, D.C.](#) office building
- [Sechelt, British Columbia](#) municipal building
- [North Vancouver, British Columbia](#) multifamily building
- [Lyon, France](#) new construction mixed use development

RETROFIT

C&I buildings are good retrofit candidates, as chiller systems in existing C&I buildings can be integrated with WET systems to eliminate cooling towers (see [Richmond, British Columbia](#) theatre case study). WET is advantageous because in summertime, while wastewater may be 80°F, it still provides a better temperature delta for chiller systems than cooling tower temperatures between 85°F and 95°F (AECOM 2025).

Read more about retrofit WET system projects in the following case studies:

- [Bronx, New York](#) multifamily building
- [Toronto, Ontario, Canada](#) hospital
- [Richmond, British Columbia, Canada](#) theater
- [Leukerbad, Switzerland](#) spa

Specialty C&I: Wastewater Treatment Plants

Municipal wastewater treatment systems in the US consume approximately 30 billion kWh annually, and their operations are typically the largest energy users in a community. Individual wastewater facilities currently consume about five times more energy than is needed to treat their water flow—meaning that some wastewater treatment plants have energy use intensity (EUI) five times the high-efficiency baseline. Energy use in wastewater treatment facilities is expected to increase by up to 20 percent in the future, due to more stringent water quality standards and growing water demand based on population growth. Reducing energy usage in these facilities can yield significant environmental, economic, and social benefits for local communities (Better Buildings Solution Center 2025).

Wastewater treatment plants are uniquely positioned to implement a specialized form of WET: sanitary wastewater energy exchange, which can recover excess heat from wastewater prior to its treatment and/or discharge to use at or near a water resource recovery facility. Some industrial wastewater systems have a large volume of low-grade heat available in their wastewater and can typically provide a 20°F to 25°F temperature delta (AECOM 2025). The payback period is typically

short—less than two years—but this varies and is a direct function of the distance between the heat source and where it is used (NYSERDA 2019).

Some wastewater treatment plants are driven to pursue WET because regulations require that effluent released into natural bodies of water be no warmer than temperatures that support aquatic and amphibious flora and fauna. For example, Metro Denver Water Recovery in Colorado has pursued WET because the facility must reduce the temperature of its effluent released into the nearby river by 14.4°F.

Read more about a WWTP WET system project in the following case study:

- [Sechelt, British Columbia](#) WWTP (new construction)

District Energy Systems

District energy projects can involve new construction and retrofit scopes to achieve thermal energy networks connecting heat sources and sinks with buildings with heating and cooling demands.

District energy systems or networks of connected buildings are excellent candidates for WET, as they can integrate with WWTPs and balance space cooling, space heating, and DHWH demands for multiple buildings. WET is ideal for district energy systems because the return on investment for district energy and WET depends on density of buildings with cooling and/or heating demand (AECOM 2025).

Read more about district energy WET system projects in the following case studies:

- [Denver, Colorado](#) district energy system
- [False Creek, Vancouver, British Columbia](#) district energy system
- [Sen'ákw, Vancouver, British Columbia](#) district energy system
- [Markham, Ontario, Canada](#) district energy system

DISTRICT COOLING

District cooling systems may use electric chillers (like the Cordia system in San Diego), ice storage, or geothermal heat pumps connected to energy transfer stations with district heat exchangers (AECOM 2025, Gautier et al 2022). WET has been applied to district cooling systems when connected to heat pumps, which provide both cooling and heating to connected buildings. Additionally, WET improves the temperature differential for geothermal heat pump district cooling applications.

DISTRICT HEATING

District heating systems have historically been driven by fossil fuels like natural gas. However, some district heating systems use geothermal heat pumps, like district cooling systems. The temperature differential for a heat pump is better for wastewater (58°F to 60°F) than geothermal (45°F to 55°F), which can make a business case for WET stronger in district heating applications (AECOM 2025).

THEMAL ENERGY NETWORKS

Public and private entities have operated thermal energy networks (TENs), including district energy systems, for decades; however, regulated utilities require state legislation to build TENs. Since 2021, seven states—including California—have passed legislation that mandates or allows regulated utilities to develop pilot TEN projects, with a goal of proving viability as a utility-scale clean energy solution (Building Decarbonization Coalition 2024).

Figure 9 shows that California passed TENs legislation in 2024 via Senate Bill 1221, the Priority Neighborhood Decarbonization Act, which allows the state’s gas utilities to pilot cost-effective neighborhood-scale decarbonization projects—up to 30 statewide—in lieu of replacing gas pipelines. The act specifies that these zero-emission pilots may take the form of “neighborhood electrification” or thermal energy networks, and includes the following provisions:

- Authorizes the California Public Utilities Commission (CPUC) to update a utility’s requirement to provide methane gas in a pilot area, so long as the utility receives consent from 67 percent of its customers and provides a new energy type that is “reasonably available to support the energy end uses” of affected customers.
- Pilots should prioritize disadvantaged and low-income communities, include tenant protections, and give preference for prevailing wages and high-road job programs (Building Decarbonization Coalition 2025).

For the two California IOUs that are both gas and electric utilities—PG&E and SDG&E—this represents an opportunity to serve “both sides of the house.”

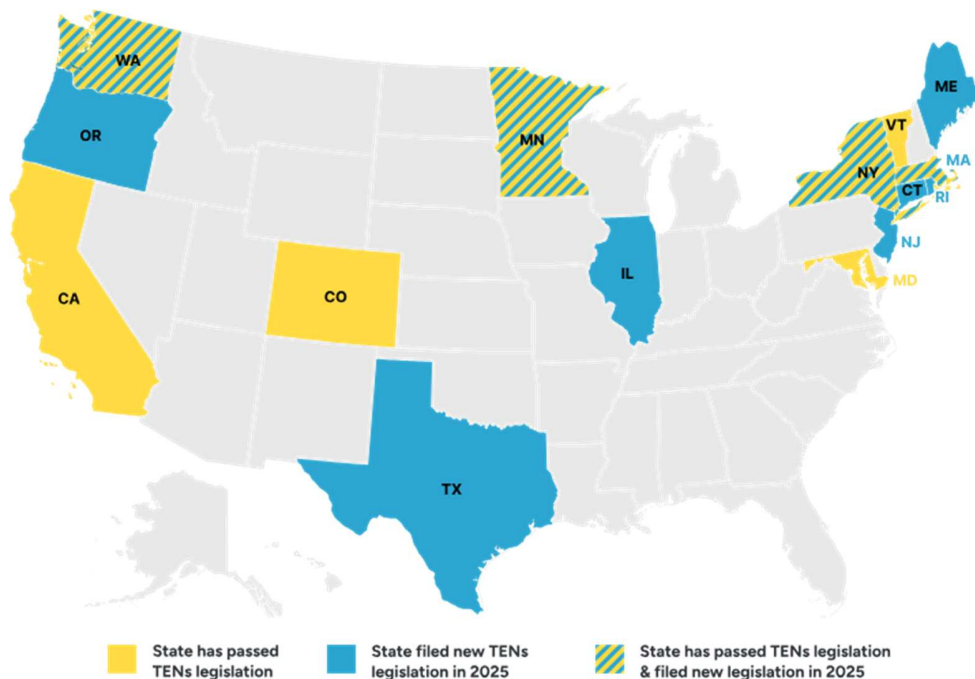

Figure 9: United States thermal energy network legislation status, 2025.

Figure data source: Building Decarbonization Coalition 2025.

TENs in design and operation in the US tend to incorporate geothermal heat pumps (see Figure 10). WET systems can offset a portion of the necessary geothermal heating and cooling capacity for TENs by offering a second heat source/sink. This reduces the cost of drilling for boreholes, which can account for up to 50 percent of geothermal system costs (Amer et al 2025). District energy systems using WET have been demonstrated in multiple places in the US.



Figure 10: District energy system.

Figure data source: Building Decarbonization Coalition 2025.

Product Overview

There is an opportunity for a new C&I WET measure to fill a gap in existing California IOU energy efficiency program offerings, as there is no heat recovery measure for wastewater for any types of nonresidential building in 2025.

Three types of closed-loop WET systems are being evaluated in this market assessment:

1. The first group of WET products evaluated for this market assessment are from Manufacturer A. Capacities of units for multifamily applications range from 60,000 – 180,000 Btu per hour while capacities of units for larger commercial, industrial, and agricultural applications range from 250 kW to 1.5 MW.
2. The second group of WET products evaluated for this market assessment are from Manufacturer B. Their units have a modular design and are custom sized to meet capacities of several hundred kW.

Each WET system is different, so C&I buildings can use banks of these WET products to meet necessary heating and/or cooling capacity requirements. Some WET systems are paired with pumping station screens to filter particulates from the wastewater stream before entering the heat exchanger.

Product costs for WET are difficult to average for California C&I buildings due to the impact project characteristics can have on the system design. Manufacturer-suggested retail price for WET infrastructure is based on an assumed 10°F temperature differential and a 5°F approach at standard wastewater temps of 70°F; system costs change with variations of temperature differential, source temperatures, and load-side temperatures. The average costs for a WET system in 2025 are impacted by ongoing trade actions between the United States, Canada, and the European Union. The cost of WET systems is a large barrier to system adoption—and these increases in product costs can impact hard-to-reach (HTR) customers and disadvantaged communities (DAC) more acutely.

Case Studies

Research Objectives

Since WET technology is still in its infancy, data from operational WET systems is limited. The existing literature and case studies documenting energy efficiency benefits are predominately from Europe and Canada.

The project team leveraged data from four domestic and 10 international case studies for WET systems currently in planning, design, construction, or operation phases, representing ASHRAE Climate Zones 4 through 6, similar to some of the California climate zones (CZs) in California IOU territory. Table 8 describes characteristics of each case study, including WET system details. Note that district energy projects are not characterized as retrofit or new construction, as that type of project generally requires both retrofit and new construction scopes for the associated infrastructure and connected buildings.

Table 8: California Energy Code requirements affecting nonresidential building systems.

Case Study Name	Location	Construction Type	Building Use Type	WET Heat Source	WET Application(s)
Amalgamated Housing Cooperative Towers	Bronx, New York, USA	Retrofit	Multifamily	Sinks, showers, toilets	Space cooling, space heating, and DHWH
Alafia	Brooklyn, New York, USA	New Construction	Mixed Use	Sinks, showers, toilets	Space cooling, space heating, and DHWH
D.C. Water Headquarters	Washington D.C., USA	New Construction	Municipal Office	Sinks, toilets	Space cooling, space heating, HWH
National Western Center	Denver, Colorado, USA	District Energy	Mixed Use	Sewer line	Space cooling, space heating, HWH

Case Study Name	Location	Construction Type	Building Use Type	WET Heat Source	WET Application(s)
Walliser Alpentherme & Spa Leukerbad	Leukerbad, Switzerland	Retrofit	Public Assembly	Showers, baths	Space heating and DHWH
La Saulaie District	Lyon, France	New Construction	Mixed Use	Sewer line	Space cooling, space heating, HWH
Markham District Energy	Markham, Ontario, Canada	District Energy	Mixed Use	Sewer line	Space cooling, space heating, HWH
Gateway Theatre	Richmond, British Columbia, Canada	Retrofit	Public Assembly	Sinks, toilets	Space heating, HWH
Regional Water Resource Centre	Sechelt, British Columbia, Canada	New Construction	Wastewater treatment plant	Sewer line	Space cooling, space heating
Toronto Western Hospital	Toronto, Ontario, Canada	Retrofit	Healthcare	Sewer line	Space cooling, space heating, HWH
False Creek Neighbourhood Energy Utility	Vancouver, British Columbia, Canada	District Energy	Mixed Use	Sewer line	Space cooling, space heating, and DHWH

Case Study Name	Location	Construction Type	Building Use Type	WET Heat Source	WET Application(s)
Seven35	Vancouver, British Columbia, Canada	New Construction	Multifamily	Sinks, showers, toilets	DHWH
Senákw Energy System	Vancouver, British Columbia, Canada	District Energy	Mixed Use	Sewer line	Space cooling, space heating, HWH
Wintower	Winterthur, Switzerland	Retrofit	Office	Sewer line	Space cooling, space heating, HWH

This list represents a sample of 14 case studies for WET; five of the sampled case studies include information provided by the project design team or a third-party evaluator. The case studies demonstrate WET equipment from Manufacturer A and Manufacturer B, which both provided the sole source of data for nine of the sampled case studies.

Manufacturer A is headquartered in Vancouver, British Columbia, and continues to develop WET projects in the city and surrounding communities and has other US projects in construction in Berkeley, California, and Seattle, Washington (Canadian Securities Exchange 2025). Manufacturer B is an international organization with a headquarters in North Carolina; as of 2021, they have installed 45 WET systems worldwide: 15 in Germany, 13 in Switzerland, and one project each in Poland, Mexico, South Korea, Denmark, Sweden, and Canada (Chartered Institute of Building Services Engineers 2021).

US Case Studies

There are four domestic case studies that demonstrate two Manufacturer A WET units being evaluated by this market assessment.

Bronx, New York, United States

Project Name:	Amalgamated Housing Cooperative – “The Towers”
Project Type:	Multifamily retrofit
Project Climate Zone:	ASHRAE Climate Zone 4A
Project Size:	425,000 sq ft
WET Configuration:	WET and ground source (geothermal) heat pump
Wastewater Source:	Sinks, showers, toilets
End Use Applications:	Space cooling, space heating, DHWH

This decarbonization project will use thermal energy transfer from the ground and wastewater to provide 100 percent of the heating, hot water and cooling load for 316 affordable housing units in two 20-story multi-family towers (3975 and 3965 Sedgwick Avenue), originally built in 1968 and 1971. “The Towers” are part of the oldest limited equity multifamily co-op in the US. The project is receiving \$19.5 million in funding from the New York State Empire Building Challenge to support low-carbon retrofit projects (NYSERDA 2025).

The design will recapture heat from sinks, showers, and toilets by re-piping the buildings for a geothermal heat pump system connected to a WET heat exchanger to enhance the energy efficiency and climate resilience of the property (Retrofit Playbook for Large Buildings 2025).

The total capital costs for decarbonization projects, including WET, are \$33 million, compared to a baseline cost of \$29.5 million. Based on maintenance costs and available incentives in New York, and excluding the state’s social cost of carbon of \$125 per ton, the project’s net present value is \$1.97 million (Ibid).

The WET and geothermal heat pump system seek to reduce Tower I and Tower II energy use from a site energy use intensity (EUI) of 111.6 to 40, representing a decrease of 2,741 carbon tons to zero tons (SHARC Energy 2022).

Figure 11 describes the existing conditions and the timeline of implementation for the new systems; the WET system was installed in 2024.

Existing Conditions

This diagram illustrates the building prior to the initiation of Strategic Decarbonization planning by the owners and their teams.

Click through the measures under “Building After” to understand the components of the building’s energy transition.

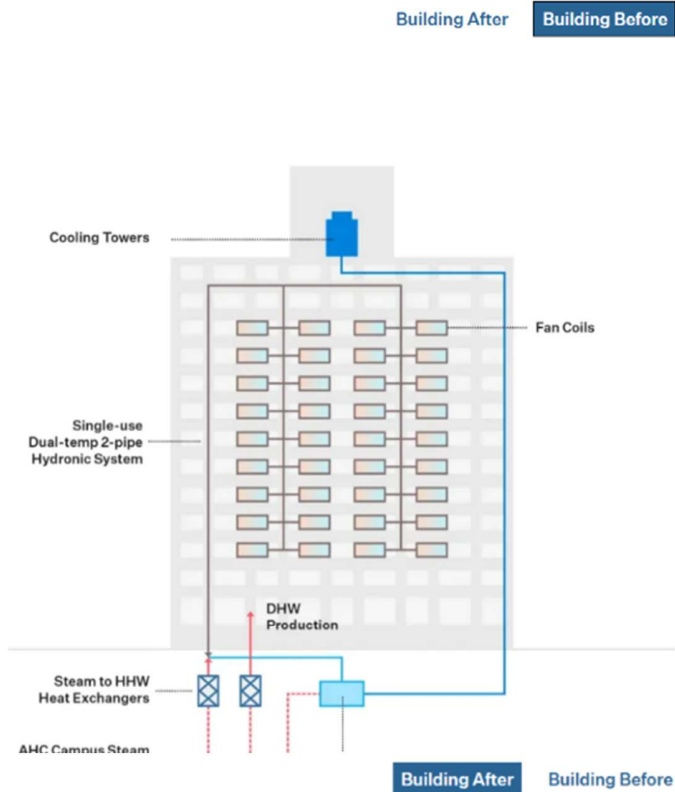

Building System Affected

● heating

Sequence of Measures

2024	<ul style="list-style-type: none"> ● Retrofit Dual-Temp Hydronic System ● Wastewater Energy Transfer (WET) System ● Ventilation System Maintenance
2026	<ul style="list-style-type: none"> ● Envelope Improvements ● Geothermal System ● Submetering and Controls Upgrades
2028	<ul style="list-style-type: none"> ● Solar PV
2030	<ul style="list-style-type: none"> ● Laundry and Cooking Appliance Electrification

Building System Affected

● heating

● cooling

● ventilation

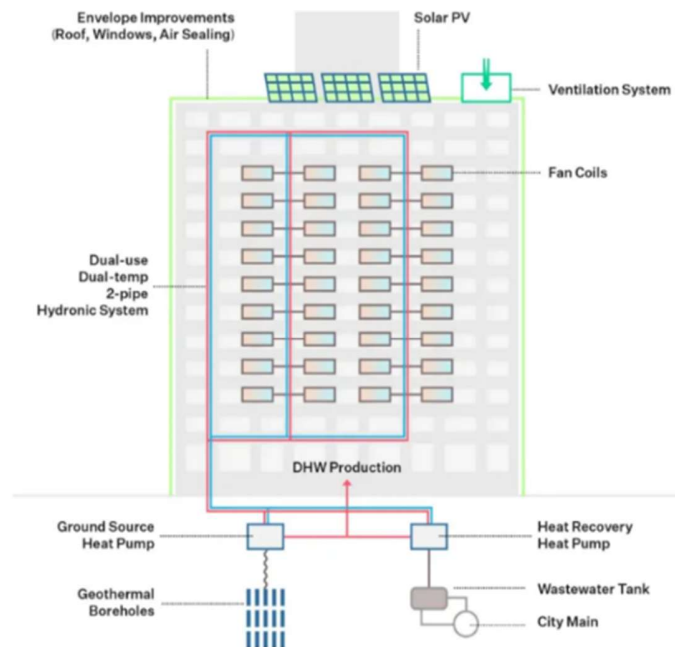

Figure 11: Amalgamated Housing Cooperative Towers WET retrofit.

Figure Data Source: Retrofit Playbook for Large Buildings 2025.

Brooklyn, New York, United States

Project Name:	Alafia
Project Type:	Mixed-use new construction
Project Climate Zone:	ASHRAE Climate Zone 4A
Project Size:	1,100,000 sq ft
WET Configuration:	WET and ground source (geothermal) heat pump
Wastewater Source:	Sinks, showers, toilets
End Use Applications:	Space cooling, space heating, hot water heating

The 27-acre Alafia project in Brooklyn, New York, includes two buildings with current design plans to include WET systems, as shown in Figure 12. Both buildings will use a closed-loop geothermal heat pump system and WET system for space heating, cooling, and hot water. The project is part of New York State's \$1.4 billion plan to address social, economic, and health disparities in Brooklyn's underserved communities. ConEdison, the project's electricity utility provider, is a project partner (SHARC Energy 2025b).

The first phase of redevelopment will include the new construction of two buildings with WET systems: a 15-story building with 452 apartments and a six-story building with 124 apartments. The 15-story building includes two towers connected by a common lobby, with a 15,000-sq ft medical clinic in the first tower, and 7,800 sq ft of retail space in the second tower (Financial Post 2023).

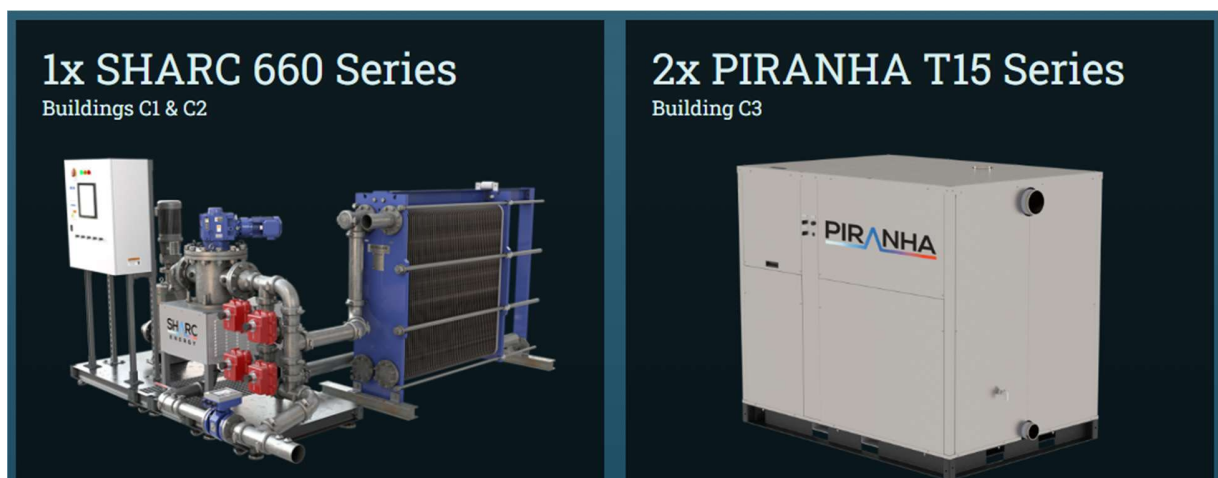

Figure 12: WET infrastructure for Alafia design.

Figure data source: SHARC Energy 2025a.

The 576-apartment project was commissioned in the second quarter of 2025 and confirmed that future phases will mirror the scalable WET design used for buildings C1, C2, and C3 (SHARC Energy 2025c).

Washington, D.C., United States

Project Name:	D.C. Water Headquarters
Project Type:	Commercial/municipal new construction
Project Climate Zone:	ASHRAE Climate Zone 4A
Project Size:	151,300 sq ft
WET Configuration:	WET plus energy recovery chiller plus boiler
Wastewater Source:	Sinks, toilets
End Use Applications:	Space cooling, space heating, hot water heating

The D.C. Water Headquarters in Washington, D.C. was constructed in 2018, with a WET system serving space heating, space cooling, and DHWH end uses. The WET system, shown in Figure 13, reduces natural gas usage for DHW by 2,320 therms per year. By eliminating the cooling tower, associated HVAC water usage is reduced by 1.5 million gallons per year (SHARC Energy 2022a). The WET system is designed to transfer 2,540 thousand British thermal units per hour (MBtuh) for space cooling and 1,653 MBtuh for space heating, for a total of 6,712 million British thermal units (MMBtu) per year—equivalent to 1,967,093 kWh per year (SHARC Energy 2025d).



Figure 13: WET infrastructure at D.C. Water Administrative Building.

Figure data source: SHARC Energy 2025b.

The WET system is connected to an energy recovery chiller, chilled beams, and a dedicated outside air system, with air handling units and variable air volume boxes, as shown in (SHARC Energy 2018).

SPACE CONDITIONING & WATER HEAT

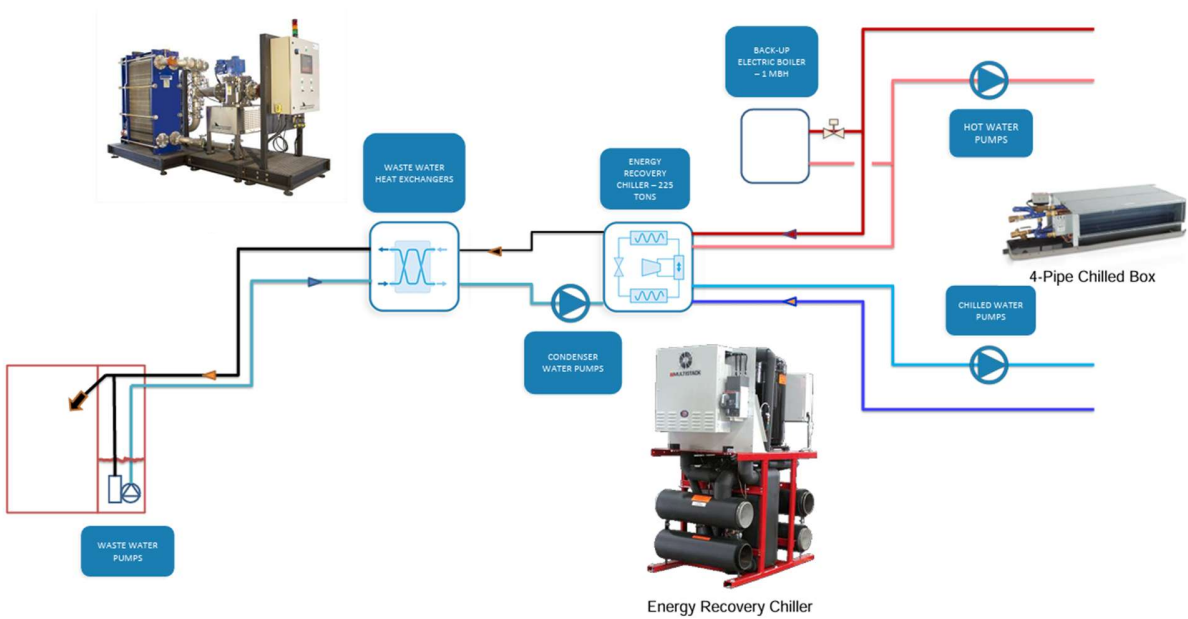
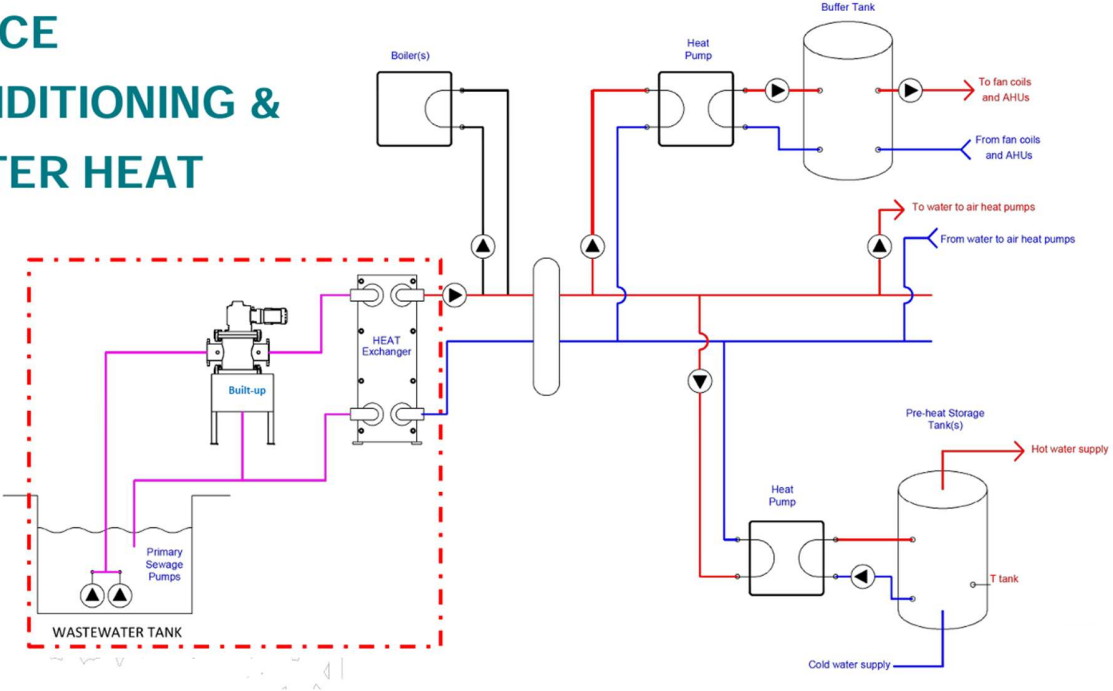

Figure 14: WET system schematics for D.C. Water Administrative Building.

Figure data source: SHARC Energy 2018.

Denver, Colorado, United States

Project Name:	National Western Center
Project Type:	District energy
Project Climate Zone:	ASHRAE Climate Zone 5
Project Size:	2,200,000 sq ft
WET Configuration:	WET
Wastewater Source:	Sewer line to wastewater treatment plant
End Use Applications:	Space cooling, space heating, hot water heating

The National Western Center sources 90 percent of its heating and cooling energy from its 4-MW WET system connected to wastewater flow from a Metro Water Recovery sewer pipeline (SHARC Energy 2025e). The system was built and operated by EAS Energy Partners (short for EAS) through an agreement with the National Western Center; EAS is comprised of CenTrio Energy, AECOM Technical Services Inc., and Saunders Construction. Partners in the district energy system and its future users include the City and County of Denver, Colorado State University, and the National Western Stock Show. Metro Water Recovery provides thermal energy at no cost and buried its sewer pipeline that runs through the National Western Center site (National Western Center 2025).

The 2015 National Western Center Master Plan set ambitious sustainability goals for the campus, including a principle to embrace an ethic of on-site regeneration. As the campus redevelopment plan came together, the City of Denver project team approached Metro Water Recovery about relocating its 78-foot aboveground interceptor pipeline, shown in Figure 15 (National Western Center 2025).

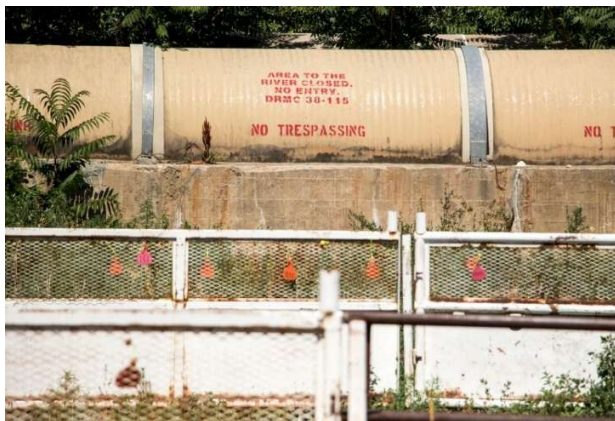

Figure 15: Aboveground effluent pipe.

Image source: National Western Center 2025.

Metro Water Recovery was open to altering their system because they were concurrently working on regulating the temperature of the clean wastewater—or effluent—that their WWTP returns to the South Platte River. Recognizing the potential environmental benefits of using thermal energy from the pipeline to heat and cool buildings, including cooling of the effluent, Metro Water Recovery conducted feasibility studies and completed further studies with the City and County of Denver, Metro Water Recovery, and Xcel Energy, which confirmed WET was technically feasible. The National

Western Center signed a long-term energy agreement with EAS in 2020 (National Western Center 2025).

AECOM located the central utility plant (CUP) 50 feet from the Metro Water Recovery interceptor pipe to minimize heat losses over a longer distance. For the WET system, AECOM considered two manufacturers: Manufacturer A (WET uses a plate and frame heat exchanger) and Manufacturer B (WET uses a shell and tube heat exchanger, which fouls and needs to be cleaned actively). The system was sized to 4 MW to sufficiently cover 90 percent of the annual energy demand; boilers shave peaks 10 percent of the time. The equipment from Manufacturer A was less expensive—the National Western Center would have needed eight 500-kW units from Manufacturer B compared to one 4-MW unit from Manufacturer A. The equipment from Manufacturer B would have required too large of a footprint inside the CUP, too much piping, and many controls. AECOM turned over the project to the operation and maintenance (O&M) partner in 2022, and there has been a drastic reduction in fossil fuel utilization because of the heat exchange with the WET system (AECOM 2025). Figure 16 shows the CUP and WET infrastructure for the National Western Center district energy

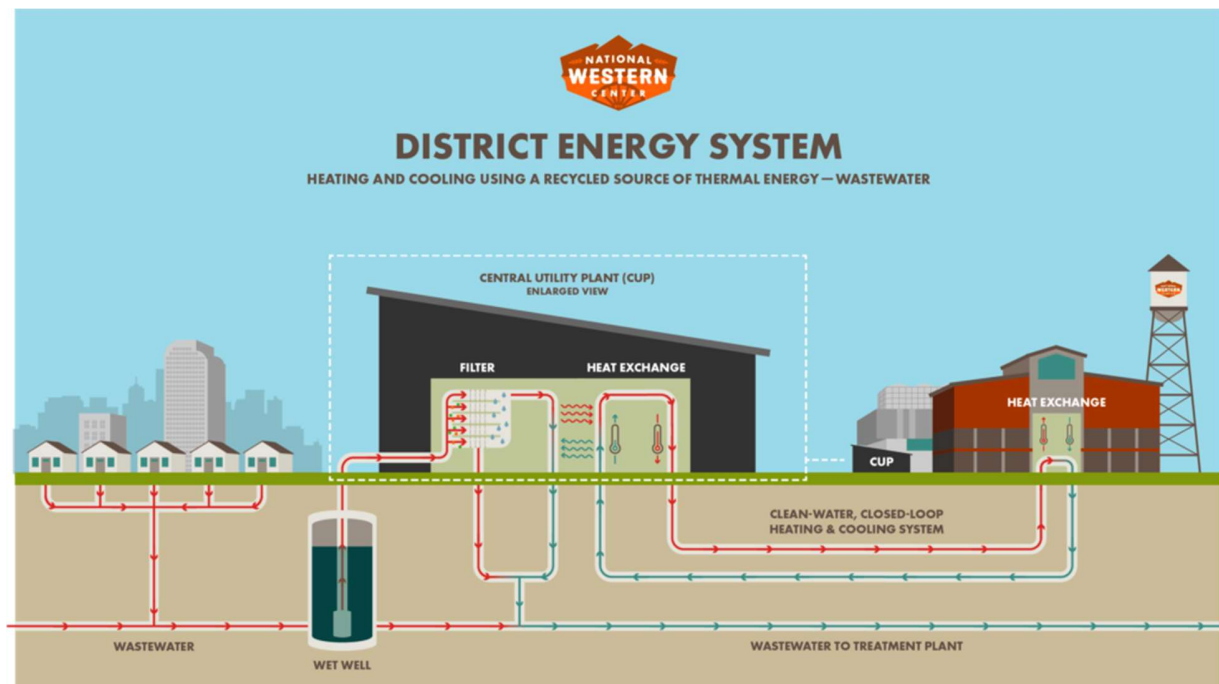

system.

Figure 16: National Western Center district energy system.

Figure data source: National Western Center 2025.

This project may continue to expand. An April 2025 Request for Proposals solicited professional engineering study services for a “Wastewater Effluent Thermal Energy Recovery and Distribution Study” for a 200-MW WET system at Metro Water Recovery’s Robert W. Hite Treatment Facility. The WET system would transfer thermal energy from Hite’s secondary or tertiary water treatment systems to Xcel Energy’s existing district energy system in downtown Denver, as well as two nearby

developments (the Ball Arena and River Mile). The business-as-usual case is 200 MW of cooling towers, estimated to cost \$82.2 million (Metro Water Recovery 2025).

The design could involve building a CUP on the WWTP side, which would provide an ambient loop to feed developments or heating and cooling loops for downtown. Since Xcel Energy already owns a steam system that they want to convert to hot water—and because they need heat—effluent water could be provided to the Xcel plant or other private developments close to downtown, or both (AECOM 2025).

International Case Studies

There are ten international case studies that demonstrate three Manufacturer A and Manufacturer B WET units being evaluated by this market assessment.

Leukerbad, Switzerland

Project Name:	Walliser Alpentherme and Spa Leukerbad
Project Type:	Public assembly retrofit
Project Climate Zone:	ASHRAE Climate Zone 4A
Project Size:	3,229 sq ft
WET Configuration:	WET and water-source heat pump
Wastewater Source:	Sewer line
End Use Applications:	Space heating, hot water heating

Leukerbad is the largest alpine thermal spa in Europe, with 10 thermal baths constantly fed from 1 million gallons of natural hot springs at temperatures of 122°F; there is a constant wastewater flow of 2 gallons per second at a reduced temperature of 86°F. In 2011, the spa was the first to use HUBER.

The tank-style heat exchangers: Two Manufacturer B WET units were installed below the parking area at the rear of the spa and covered with load-bearing covers to retain parking spaces. The WET system has a capacity of 450 kW and is connected to a heat pump system, and the WET infrastructure integrated with a heat pump provides 1 MW for heating purposes within the Burgerbad spa. This system replaced an oil-fired boiler (HUBER 2025).

Lyon, France

Project Name:	La Saulaie District
Project Type:	Mixed-use new construction
Project Climate Zone:	ASHRAE Climate Zone 5B
Project Size:	161,000 commercial sq ft
WET Configuration:	WET
Wastewater Source:	Sewer line
End Use Applications:	Space heating, hot water heating

La Saulaie is a 50-acre urban development project being planned for 630 apartments, a school, a gym, a place of worship, a sports facility, and other shops and services. The project is in the design phase and forecasts a wastewater flow of 317,000 gallons per second from the various buildings in the district. The installation of a WET system—consisting of six Manufacturer B WET heat exchangers—began in 2024. The wastewater temperatures are expected to fluctuate from 52°F to 73°F between winter and summer; the WET system has a heating capacity of 2.9 MW and a cooling capacity of 4.6 MW (HUBER 2025a).

Markham, Ontario, Canada

Project Name:	Markham District Energy
Project Type:	District energy
Project Climate Zone:	ASHRAE Climate Zone 6
Project Size:	8,000,000 sq ft
WET Configuration:	WET
Wastewater Source:	Sewer line
End Use Applications:	Space cooling, space heating, hot water heating

Markham District Energy is building an 18.5-MW WET system to supply heating and cooling for their existing customers, which, when completed, will be the world's largest WET installation and is expected to significantly reduce natural gas consumption. The Markham project has diverse funding streams, including a \$135-million loan from the Canada Infrastructure Bank; a \$135-million line of credit from CIBC; \$700,000 from Enbridge Gas; \$16.7 million from the federal Low Carbon Economy Fund; and \$8.2 million from the Green Municipal Fund (The Energy Mix 2024).

The WET system includes five pumping station screens and 16 HUBER RoWin size 14 heat exchanger units (HUBER 2025b).

Richmond, British Columbia, Canada

Project Name:	Gateway Theatre
Project Type:	Public assembly retrofit
Project Climate Zone:	ASHRAE Climate Zone 4C
Project Size:	50,000 sq ft
WET Configuration:	WET and water-source heat pump
Wastewater Source:	Sinks, toilets
End Use Applications:	Space cooling, space heating, hot water heating

The City of Richmond’s public theatre was built in 1984 and had existing water-source heat pumps connected to a natural gas boiler and cooling tower (see Figure 17); WET was an attractive retrofit option because the theatre is adjacent to an existing city sanitary lift station (SHARC Energy 2018). The WET retrofit project was designed to save between 930 gigajoules (GJ) and 1,150 GJ of natural gas annually, equal to 36 percent to 44 percent of the theatre’s 2,614 GJ of annual natural gas usage for space heating and makeup air heating (City of Richmond 2012).

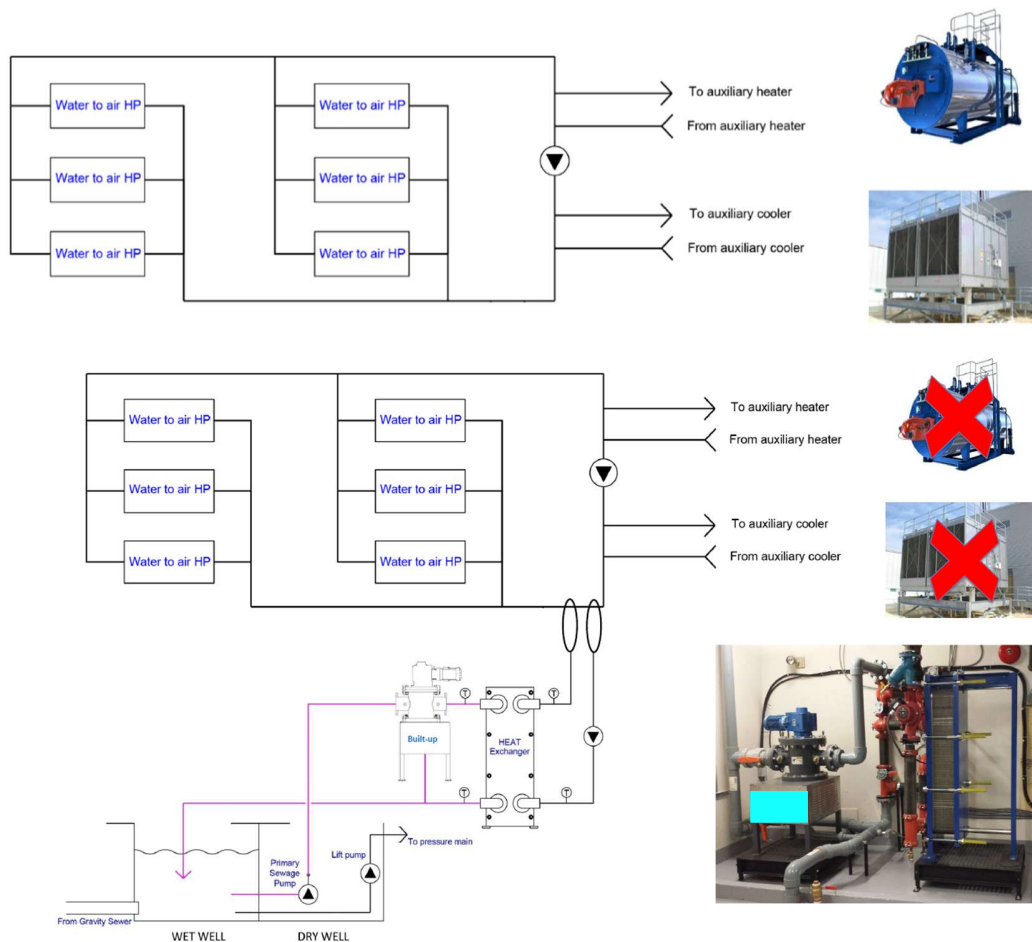

Figure 17: WET infrastructure for Gateway Theatre.

Image Source: SHARC Energy 2025a.

Sechelt, British Columbia, Canada

Project Name:	Regional Water Resource Centre
Project Type:	Municipal new construction
Project Climate Zone:	ASHRAE Climate Zone 4C
Project Size:	19,267 sq ft
WET Configuration:	WET
Wastewater Source:	Sewer line
End Use Applications:	Space heating and space cooling

The Regional Water Resource Centre, built in 2014, is a wastewater treatment facility with a WET system, shown in

Figure 18. The system provides typical heat transfer of 630,000 BTUh for heating and 500,000 BTUh for cooling, with a measured peak heat transfer of 1,500,000 BTUh. The WET system can reduce carbon emissions by 96,000 kilograms of carbon dioxide equivalent per year (SHARC Energy 2025g).



Figure 18: WET Infrastructure for Regional Water Resource Centre

Image Source: SHARC Energy 2025a.

SPACE CONDITIONING & WATER HEAT

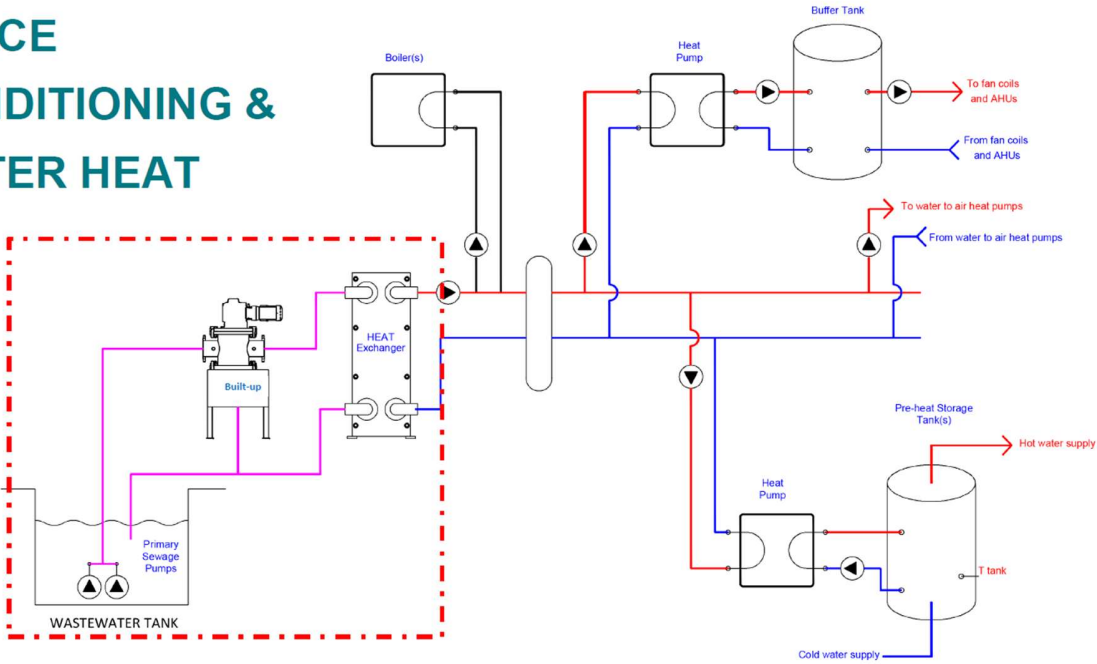

Figure 19: WET infrastructure for Regional Water Resource Centre.

Source: SHARC Energy 2025a.

Toronto, Ontario, Canada

Project Name:	Toronto Western Hospital
Project Type:	Healthcare Retrofit
Project Climate Zone:	ASHRAE Climate Zone 6
Project Size:	1,200,000 sq ft
WET Configuration:	WET and water-source heat pump
Wastewater Source:	Sewer line
End Use Applications:	Space cooling, space heating, hot water heating

The Toronto Western Hospital is a 272-bed facility located in downtown Toronto. The hospital will be the site of the world's largest "raw" WET project, supplying 90 percent of the hospital's heating and cooling requirements with over 33,000 MBTUh of heating capacity with untreated wastewater from an adjacent sewer line. The project is estimated to save 4.7 million kWh of electricity, 1.5 million therms of natural gas, and 11.4 million gallons of water for cooling towers annually. A non-energy benefit of the project identified by the health network includes easy access to wastewater samples for health research, including anti-microbial resistance and monitoring for pandemics (University Health Network 2022).

The WET system is comprised of six pumping station screens and 16 HUBER RoWin size 8 heat exchangers (Noventa Energy 2025).

Vancouver, British Columbia, Canada

FALSE CREEK

Project Name:	False Creek Energy Centre
Project Type:	District energy
Project Climate Zone:	ASHRAE Climate Zone 4C
Project Size:	6,400,000 sq ft
WET Configuration:	WET
Wastewater Source:	Sewer line
End Use Applications:	Space cooling, space heating, hot water heating

False Creek Energy Centre, which has been operational since 2010, is the largest WET project in North America (SHARC 2022b) and was the first large-scale wastewater heat recovery system in North America serving residential, commercial, and institutional space (see Figure 20). In 2017, the False Creek Neighborhood Energy Utility (NEU) produced 46 GWh and saved 3,500,000 kilograms of carbon dioxide equivalent. The same year, 32 additional buildings—including 4,700 residential units—were added to the network using 6 kilometers of underground piping (SHARC Energy 2018).

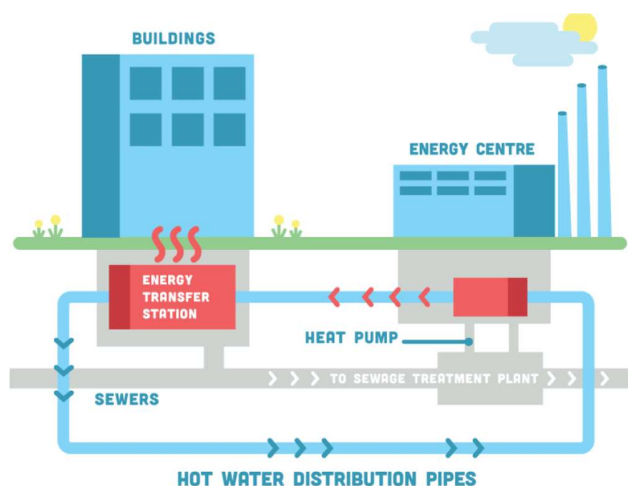

Figure 20: WET infrastructure for False Creek Energy Centre.

Figure data source: SHARC Energy 2025a.

The NEU supplies low-carbon energy for heating and hot water to 6.4 million sq ft of mixed-use buildings, including Science World and Emily Carr University, and is projected to continue growing. A WET system expansion project constructed between 2022 and 2024 added 6.6 MW to the existing 3.2 MW of capacity (City of Vancouver 2025). The NEU has expanded by 300 percent since its inception and now uses a total of eight Manufacturer A WET units to serve the thermal energy network (SHARC Energy 2025h).

NORTH VANCOUVER

Project Name:	seven35
Project Type:	Multifamily new construction
Project Climate Zone:	ASHRAE Climate Zone 4C
Project Size:	50,000 sq ft
WET Configuration:	WET and ground-source (geothermal) heat pump
Wastewater Source:	Sinks, toilets
End Use Applications:	DHWH

The seven35 project is a 60-home community, served by a WET system shown in Figure 21; the bottom left image is of the original system installed in 2012. The WET system reduces DHWH natural gas energy use by preheating water to 125.6 °F (52 °C). A WET system retrofit was completed in 2016 (see bottom right image in Figure 21).

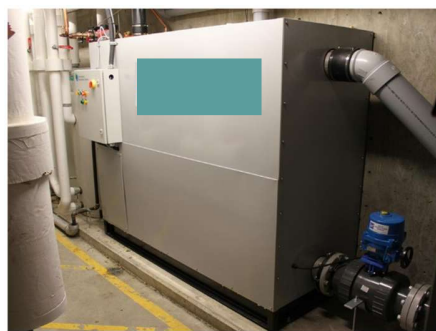
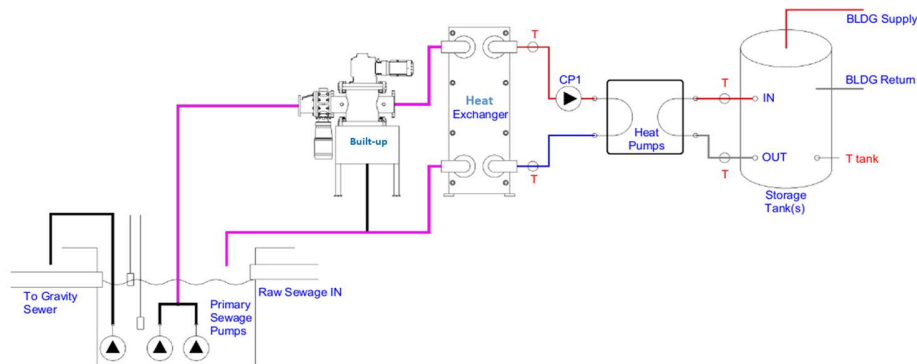

Figure 21: WET Infrastructure for seven35

Image Source: SHARC Energy 2025a.

Two years of energy data, validated by a third party, confirmed the WET system reduced the boiler systems' energy usage from 746.87 kWh per day to 205.75 kWh per day (converted from natural gas usage to equivalent kWh) in August 2012. This is equivalent to 75 percent DHWH natural gas savings (International Wastewater Heat Exchange Systems 2013, SHARC Energy 2025f).

SEN'ÁKW

Project Name:	Sen'ákw Energy System
Project Type:	District energy
Project Climate Zone:	ASHRAE Climate Zone 4C
Project Size:	4,000,000 sq ft
WET Configuration:	WET
Wastewater Source:	Sewer line
End Use Applications:	Space cooling, space heating, hot water heating

The largest real estate development in Canadian First Nations history will use WET for a district energy system. This project not only represents the first private development in British Columbia to leverage Metro Vancouver's Sewage and Waste: Heat Recovery policy—it also marks the first private residential development in Canada to harness an external sewer force main as its primary energy source (SHARC Energy 2025i). Creative Energy is partnering with the Squamish Nation's economic development arm, Nch'kay Development Corporation, and construction is ongoing in 2025. Figure 22 shows the two tapped 16-inch diameter connections into Metro Vancouver's 47-inch diameter sewer main. Hot tapping is the process of drilling into a live pressurized pipe without shutting down the piping system to maintain normal sewer operation (Creative Energy 2025).



Figure 22: Hot tapping sewer main.

Winterthur, Switzerland

Project Name:	Wintower
Project Type:	Office retrofit
Project Climate Zone:	ASHRAE Climate Zone 4A
Project Size:	237,000 sq ft
WET Configuration:	WET and water-source heat pump
Wastewater Source:	Sewer line
End Use Applications:	Space cooling, space heating, hot water heating

The 28-story Wintower office building was renovated in 2010 to use a WET system connected with the adjacent sewer interceptor line. During dry weather, the wastewater flows in the sewer line are around 42 gallons per second; one pumping station screen and two HUBER RoWin heat exchanger units use 13 gallons per second of wastewater and pretreat it with a pumping station screen. The WET system is connected to a heat pump to generate heating and cooling for a resulting COP of around 4.0. The WET system provides 585 kW of heat in winter and 600 kW of cooling in summer, with an electrical power input of around 150 kW (HUBER 2025c).

WET Benefits

WET applications in C&I buildings can provide diverse non-energy benefits that may promote a faster adoption of WET system than energy savings alone. A summary of WET non-energy benefits is provided in Table 9.

Table 9: WET non-energy benefits.

Non-Energy Benefit	Details
Eliminates cooling towers and their water usage	Can eliminate the need for cooling towers for chillers (required space and capital expense) and their associated water consumption
Eliminates cooling tower noise pollution	Can eliminate the need for cooling towers for chillers and their associated noise pollution
Supports solar energy generation infrastructure	Eliminating cooling towers can free up space for rooftop solar photovoltaic panel arrays
Reduces the necessary capacity of heat pump systems	WET offsets some cooling and/or heating capacity (ex. ground source heat pump borefields can be smaller by up to 45%)
Integrate with heat pump systems	Support electrification of space heating and hot water heating systems
Lowers pretreatment costs for WWTPs	Reduces the amount of pretreatment chemicals required for conditioning wastewater at WWTPs
Help WWTPs comply with regulations	WET systems can reduce effluent temperature for wastewater treatment plants discharging into natural bodies of water
Access to wastewater samples	Healthcare facilities with WET systems can use the infrastructure to sample wastewater for viral load (ex. COVID-19 pandemic)

Table data source: ERI. 2025d.

Energy Savings

The energy savings of WET in California IOU EE program territory presents a compelling case to continue the investigation of the technology by California IOUs. Energy savings potential for WET in California's nonresidential buildings can be estimated using theoretical energy savings calculations; the energy savings potential for electricity energy savings from space cooling and natural gas energy savings from DHWH and space heating are summarized in Table 10 and Table 11.

Energy savings calculations use aggregated energy based on breakdown data from the California Commercial End-Use Survey and apply estimated efficiency gains to two commercial building use types: large office and large multifamily housing. These market sectors were selected as:

- They are suitable for WET as demonstrated in domestic and international case studies due to consistent wastewater flows. Large office buildings have typical wastewater flows of 5,560 GPD and large multifamily housing buildings have wastewater flows of 18,730 GPD.
- The existing building stock for these two use types is significant; even at a low adoption rate, there are thousands of buildings where WET is feasible in IOU territory.
- The new construction planned for these use building types presents another substantial source of energy savings and electrification opportunity. For example, large office buildings made up 15 percent of the 12 billion sq ft of commercial buildings in California in 2022, or 1.8 billion sq ft of building area (CEC 2024).

Energy savings calculations were designed to be easily expandable to include other end uses and market sectors.

The team calculated WET savings potential for three energy end-uses: space cooling, space heating, and DHWH. For the sake of estimating a market-level savings potential, a base unit of 100,000 sq ft to generalize savings potential for large office and large multifamily housing. Each of these 100,000 sq ft example buildings would require one WET system with 750 kW capacity.

These calculations reflect a "unit of WET savings" for 100,000 sq ft of commercial building, which can be extrapolated to a percentage of C&I buildings in California IOU territory. For example, a conservative adoption rate of 1 percent for the 12 billion sq ft of California's commercial buildings would equal 120 million sq ft, the equivalent of 1,200 units of WET savings.

Market-level savings permutations for each California CZ will be possible, with more detailed information gleaned from site visits in the next phase of the project. Market-level savings can be analyzed with more accuracy when a conservative (yet realistic) adoption rate can be used and applied across office and multifamily housing buildings in California IOU territory greater than 100,000 square feet in size.

Table 10 summarizes a unit of WET electricity impacts of applying WET to eliminate cooling tower for electric water-cooled chiller for space cooling (scenario 1) in one 100,000 sq ft office building and one 100,000 sq ft multifamily housing building.

Table 10: Annual facility-level electric WET savings potential.

WET Application Number	Details	Large Office WET Savings (kWh)	Large Multifamily WET Savings (kWh)
1	Space Cooling WET Replacing Water-Cooled Electric Chiller Cooling Towers	127,311	106,109

Table data source: ERI 2025d.

The baseline for WET for space cooling is an electric water-cooled chiller (scenario 1). Scenario 1 demonstrates an average California electricity savings potential of WET heat exchangers and involves replacing or eliminating electric chiller cooling towers.

Table 11 summarizes the impacts of applying a unit of WET natural gas systems in two scenarios: WET heat recovery for natural gas boiler for space heating (scenario 2) and WET heat recovery for natural gas boiler for DHWH (scenario 3) in one 100,000 sq ft office building and one 100,000 sq ft multifamily housing building.

Table 11: Facility-level natural gas WET savings potential.

WET Application Number	Details	Large Office WET Savings (therms)	Large Multifamily WET Savings (therms)
2	Space Heating WET Heat Recovery for Natural Gas Boiler	27,439	36,585
3	DHWH WET Heat Recovery for Natural Gas Boiler	2,439	12,195

Table Data Source: Ibid.

Scenario 2 demonstrates the average California natural gas savings potential of WET heat exchangers recovering heat for natural gas boilers for space heating applications, while scenario 3 demonstrates the average California natural gas savings potential of WET heat recovery for DHWH applications.

Market Assessment Objectives

This section describes the diverse approaches taken for stakeholder outreach and engagement for this market assessment. The technology assessment portion of this project examines new measures that may remove market barriers and improve market penetration. To characterize the state of the nonresidential buildings market in California, the project team conducted surveys and interviews to gain insight from various stakeholders across the commercial, industrial, and agricultural industries. Data analysis was performed to determine the energy savings over the incumbent technology.

Customer Surveys

The objective of conducting customer surveys was to gather information about building system characteristics and installed HVAC and heat recovery systems, as well as to gauge awareness and customer understanding of WET technology. The survey was also used to collect data regarding type of nonresidential facility, size of facility, and interest in WET system adoption.

Stakeholder Interviews

The team used stakeholder interviews to corroborate information gathered from customer surveys by getting insights from building owners, managers, and industry subject matter experts that work closely on WET systems and district energy projects in North America. Interviews also aimed to collect additional data on the level of WET adoption throughout the state of California, WET applications, and recommended measure approach.

Customer Site Visits

Site visits at facilities across California were used to corroborate information gathered from customer surveys and interviews by gathering insights from the field visits to document electrical power distribution and building system characteristics. Site visits also aimed to identify energy efficiency opportunities, collect information about the level of adoption of WET technology, and identify specific barriers for nonresidential buildings to implement energy efficiency projects. The scope of the site visits for the project was observation only; WET technology was not installed at any site.

Market Assessment Methodology and Approach

This section of the report summarizes the outcomes of stakeholder outreach and engagement activities.

Table 12 summarizes the results of the assessment mechanisms. The project reached the targeted number of individuals for surveys and interviews; ERI surveyed four building owners/facility managers and interviewed four buildings industry stakeholders between April 2025 and August 2025.

Low response rates reflect a turbulent period for outreach in California due to political and economic factors that are affecting all emerging technology projects in 2025. While click rates for survey invitation emails were typical and 411 contacts visited the survey link, the survey response rate was less than 1 percent. Individuals contacted for stakeholder interviews had low interest in participation for various business reasons.

Table 12: Stakeholder engagement summary.

Stakeholder Engagement Instrument Outreach Mechanism	Target Number of Contacts	Individuals Contacted	Click Rate	Respondents	Response Rate
Surveys	800 – 1,000	12,373	6.5%	4	<1%
Interviews	6 – 10	2,872	N/A	4	<1%

Table data source: ERI 2025b, ERI 2025c.

Market Assessment Results

The sections below provide detailed insights from the market assessment's feedback mechanisms: [surveys](#), [interviews](#), and [site visits](#).

Survey Results

Input from the owners and property managers of four nonresidential buildings between April 2025 and August 2025 is analyzed below. See [Appendix A](#) to view the questionnaire provided to survey respondents.

Survey respondents represented nonresidential facilities primarily located within the greater San Francisco Bay Area. Survey respondents provided representation for two out of the 16 California CZs: CZ03 and CZ04. Facilities included in the study were constructed relatively recently, with the oldest surveyed facility built in 1995, and the newest built in 2021; the median facility age included in the study is 14.5 years (ERI 2025b).

75 percent of survey respondents operate or manage office buildings, while 25 percent of respondents represent industrial or manufacturing buildings. This indicates that the survey results provide representation for one of the most promising applications for WET analyzed in this study.

Water-cooled chillers—i.e., chillers with cooling towers—are used by 75 percent of facilities represented in the survey results. The survey results emphasize the opportunity for WET savings from eliminating cooling towers.

Only 25 percent of respondents use heat pump water heaters, while the rest use electric resistance water heaters. Although none of the survey respondents reported using boilers, this does not reflect industry standard practice in California. This is likely because survey respondents operate or manage facilities less than 10,000 square feet in size. While the survey results do not align with our energy savings baseline, they reflect that a dual baseline for DHWH may be required to account for WET systems integrating with or eliminating electric hot water heating systems.

Most respondents indicated they had no awareness or interest in installing WET systems at their facilities. This highlights the need for educational campaigns to inform California IOU customers of the business benefits of WET systems.

Respondents' primary concern about efficiency projects is the first cost of materials and labor, which presents a barrier for WET systems, as the infrastructure is significantly more expensive than the baseline equipment.

Payback periods of one to two years are preferred by 100 percent of survey respondents—another barrier for WET systems, which often have payback periods longer than two years.

Interview Findings

Conversations with industry subject matter experts complemented findings from property manager surveys. The interview findings align with survey results in some ways, but offer additional perspectives from different types of industry stakeholders.

The research team interviewed WET system designers, equipment vendors, energy consultants, and building managers to understand emerging technologies and new products. The research team experienced similar challenges with gathering input from building owners and managers, as seen in the survey feedback mechanism; no California building operators responded to interview requests during the outreach period.

This section anonymizes interviewee affiliation by using industry segment and a unique letter to identify each subject matter expert as described in Table 13. Table 13The input from four interviewees is representative of several key stakeholders transforming the California buildings market.

Table 13: Interview summary.

Stakeholder Type	Location	Number of Stakeholders	Stakeholder IDs
Equipment Manufacturers	Global with projects in California	1	WET System Manufacturer A
Facility Designers	California	2	Design Engineer A Design Engineer B
Energy Policy Expert	California	1	Code Expert A

Source: ERI 2024d.

Policy Commentary

Requirements for heat recovery or heat transfer with wastewater are not being considered for the 2028 California Energy Code (Title 24), according to Code Expert A. This suggests that baselines and savings forecasts for energy efficiency program offerings developed for WET systems do not need to account for a code change in the near term.

Manufacturer Commentary

WET System Manufacturer A shared that California is a regional sales target for North American WET system manufacturers. However, there currently are not any WET systems in operation in IOU territory. There are several sales leads in the pipeline and WET equipment has been specified in some California project designs at large commercial facilities undergoing multiphase retrofits over many years. This suggests that design assistance and electrification support, such as that offered by

the California Energy Design Assistance (CEDA) program, could be an effective way to break down barriers for WET projects in California.

Design Commentary

Design Engineer A is involved in a large capital renovation at an airport serving the San Francisco Bay Area that wants to avoid combustion-based technologies and move toward zero emissions in buildings and vehicles. The facility has two WWTPs: a municipal one that processes “domestic” wastewater generated by the restrooms and restaurant at the airport (commercial foodservice dishwashing, handwashing sinks, and toilets). The second WWTP processes deicing chemicals and other industrial airport wastewater. The airport’s domestic wastewater runs through a digester at the WWTP, which processes it into sludge and produces biogas. According to WET System Manufacturer A, the airport project team is specifying a WET system to integrate with the municipal WWTP and HVAC and DHWH systems that serve areas undergoing renovation.

Design Engineer B is a member of the [National Western Center](#) district energy design team. The following takeaways are useful to district energy systems integrating with WET:

1. The baseline for comparison is commercial-grade boilers and chillers, while the WET district energy system uses industrial-grade equipment (which is generally more robust and has much longer useful equipment life). This means that for feasibility assessments, the business-as-usual case must account for the initial capital investment, as well as equipment replacements every 10 years.
2. Initially, there were flow fluctuations on the wet well on the side of the pipe connecting into the interceptor. Because the depth of the wastewater influences what enters the wet well and the CUP, low flow can present problems for sufficient heat transfer. Between 1:00 a.m. and 7:00 a.m., there is a low depth and low flow of wastewater in the pipe, which does not reach the minimum flow target of 3,000 gallons per minute. As a result, the design team adjusted the operation of the CUP.
3. Solids in the wastewater flows were much higher than anticipated, so the project team installed a straining system in between the wet well and just before the WET system to remove more particulates. Even if WET system manufacturers say that no screening is required upstream, this designer would not recommend it.

Site Visit Results

Site visits and discussions with facility managers at nonresidential facilities in California complemented findings from customer surveys and industry stakeholder interviews. The team observed equipment and systems serving four facilities in three California climate zones, with an average facility size of 257,500 sq ft. Table 14 describes the four commercial buildings the team visited in July 2024, along with the characteristics of each building and their wastewater infrastructure. Refer to [Appendix C](#) of this report for detailed site visit reports for each facility.

Table 14: Site visit summary.

Facility ID	Climate Zone	Facility Square Feet (sq ft)	Wastewater Treatment Approach	Wastewater Source(s)	WET Feasibility
Hospital A	CZ02	350,000	Self-managed wastewater pond	Restrooms, showers, kitchens	Low
Hospital B	CZ13	230,000	Municipal sewer line	Restrooms, showers, kitchens	High
Food Processing Facility A	CZ13	150,000	Self-managed wastewater pond	Industrial heat processes	High
Commercial Office A	CZ03	300,000	Municipal sewer line	Restrooms, showers	Medium

Source: ERI 2025e.

Site Visit Findings

Site visits confirmed baselines for building-level wastewater sources and flows, identified potential WET end-use application(s), and verified optimal WET system configuration (including building-level energy transfer or sewer-level energy transfer). Findings from site visits aligned with information gathered in literature review; feasibility for commercial buildings to adopt WET technology was higher for larger buildings with consistent wastewater flows. The site visits confirmed barriers to efficiency identified in surveys and interviews, including lack of awareness and understanding of WET technology.

The research team visited large buildings, as facilities with greater heating and cooling demands and wastewater loads can be better candidates for WET. Observations at three commercial buildings—and one agricultural campus with three building types (food processing, office, and warehouses)—identified the following barriers to WET system adoption in California nonresidential buildings:

- WET costs are lowest when wastewater sources, WET heat recovery equipment, and building HVAC and DHWH systems are in proximity. Some buildings did not have easy access to wastewater infrastructure. One of the sites the team visited has an on-site wastewater treatment pond, but it is located one mile away from the campus of buildings down a steep hillside. Additionally, the sewer risers at the office building site are not all accessible for a WET retrofit.
- The age of some buildings' existing HVAC and wastewater infrastructure may make WET adoption more challenging for some campus settings, such as hospitals.
- The capacity to accommodate new equipment in mechanical rooms in existing buildings is not a guarantee. A site visited may have no room for WET heat exchangers, despite being a good candidate for WET heat recovery for a chilled water plant.

Opportunities for WET Adoption

Observations at site visits uncovered solutions for barriers to WET system installations in California IOU territory.

- WET systems can reduce strain on cooling systems to achieve electricity savings in multiple types of C&I buildings, and WET heat exchangers can reduce cooling loads for cooling towers and chillers.
- Buildings with cooling systems operating at design loads are better candidates for WET because the facilities need more cooling capacity.
- Chillers and cooling towers were observed at each of the four visited sites. WET heat exchangers could feasibly connect to cooling systems at these sites to reduce electricity consumption by using on-site wastewater sources as a heat sink.
- Effluent from industrial processes can require cooling before piping to wastewater treatment systems (self-managed or municipally managed). Industrial buildings can use 6 million gallons of water per day for food processing activities that heat water to a temperature of 140°F to 185°F. WET infrastructure can bring effluent down to 100°F and reduce loads on cooling towers.
- When applied at industrial facilities, heat recovered from effluent can serve the hot water supply and pre-heat water used for industrial processes.

Recommendations

This section explores the impact of the market assessment results. The team used the inputs from the literature review, surveys, interviews, and site visits to create measure descriptions for WET infrastructure that reduces energy use from systems in nonresidential buildings.

Measure Descriptions

This market assessment determined that WET has promising electricity energy savings potential, as well as some Total System Benefit (TSB) natural gas savings from decarbonizing space heating and DHWH systems. Table 15 demonstrates the three measures that California IOUs can develop to achieve energy savings in large office and large multifamily housing applications in California CZs. See the [Energy Savings](#) section of this report for facility-level energy savings estimates.

The energy savings estimates for WET in process heating and cooling applications for agricultural and industrial buildings are significantly impacted by the specific product being manufactured or processed; the energy savings potential for WET in these applications can be high. However, system variability is also high. The team did not model potential energy savings ranges due to the wide range of results available for dozens of industrial and agricultural cooling processes.

Table 15: WET measure descriptions.

Scenario	Measure Name	Measure Description	Energy Savings Potential
1. Space Cooling	WET for Space Cooling	WET heat exchangers connected to chillers for heat exchange	13–16% electricity savings
2. Space Heating	WET for Space Heating	WET heat exchangers connected to boilers or heat pump systems for heat recovery	5% natural gas savings
3. DHWH	WET for DHWH	WET heat exchangers connected to boiler systems for heat recovery	4% natural gas savings

Table Data Source: ERI 2025d.

Market Assessment Findings

The impact of this market assessment's findings on the nonresidential buildings market and key industry stakeholders, including California IOUs, are as follows:

- Within California's over 12 billion sq ft of commercial buildings, large office, large multifamily, healthcare, and industrial food processing buildings present the largest market for WET systems.
- Managers of C&I buildings in California IOU territory with electric water-cooled chillers show interest in learning more about WET system benefits.
- Incentive programs for a WET measure identified in this market assessment would not be affected by requirements of the 2025 version of California's energy code. The evolving state energy code may drive market adoption of WET as it accelerates the electrification of building systems like space heating and water heating and mandates the installation of electric vehicle (EV) charging infrastructure.
- There are two primary manufacturers demonstrating WET technology globally (Manufacturer A and Manufacturer B). In North America, Manufacturer A is a Canadian manufacturer deploying WET systems in the US, though not yet in California. Industry acceptance is low in the United States because operators perceive partial heating to not be worth the investment (NYSERDA 2019).
- The ideal sectors and building types for WET technology are large C&I (specifically office, multifamily, wastewater treatment plants, and manufacturing facilities managing effluent), district energy systems, and thermal energy networks. An initial energy savings estimate of WET applications for large office and multifamily building types describes an order of electricity savings in space cooling applications, as well as electrification savings in space heating and DHWH applications that is worthy of further study in field demonstrations.
- Program financial support for projects would help reduce significant cost barriers for efficiency projects installing WET systems at buildings in DACs or in facilities owned or leased by HTR customers.
- Due to economic policy changes affecting global trade in 2025, WET system costs experienced significant volatility. This may continue in 2026 and affect the cost effectiveness of WET projects in California.
- WET technology can be optimized for energy savings, demand reduction, and heating load reduction in target nonresidential WET markets by being connected to wastewater treatment plants, tapping sewer lines close to buildings, and integrating geothermal heat pumps.
- The research team documented the primary barriers to WET system adoption in California IOU territory:
 - C&I building owners and managers have low awareness of WET technology energy and non-energy benefits.
 - There is a high incremental cost between baseline systems (chillers, boilers, and heat pumps) and WET, especially without rebate programs.
 - Some chiller and boiler configurations in existing buildings are not compatible with WET and may require an associated electrification project.

- Some buildings do not have sufficient wastewater flows at the component level to support building-level WET systems, and will instead need to connect to a sewer line to achieve sufficient heat recovery.
- Some buildings' wastewater piping is not accessible for integration with a WET system.
- Some buildings' mechanical rooms are space-constrained and do not have room for a WET heat exchanger.
- Use of low-grade heat from WET heat exchangers can pre-heat industrial process streams but is insufficient to completely heat some industrial process water.
- Customers may not trust that WET systems are self-cleaning or may find that particulate buildup clogs the heat exchangers. Pre-screening at wet wells and/or pumping stations can be required.
- Sewer lines can be an effective wastewater source for single-building WET systems and district energy systems alike, but sewers may not be owned by the same entity as the C&I buildings served by the sewer.
- For sewer line WET applications, proximity to the piping is key. Distances exceeding 50 feet reduce heat transfer opportunities.
- Long distances between heat recovery sources and the application of heat can also make WET applications economically infeasible due to drilling and piping costs.
- Sewer WET systems require coordination with wastewater treatment plant owners and stakeholders to achieve project goals on a shared schedule.
- Disruptions may occur during installation of piping and equipment during start-up for WET systems.
- Sewer line connections for WET systems may require hot tapping to maintain sewer operation.

Conclusions

The results of this market assessment indicate that WET systems are an emerging technology with promising applications for C&I buildings in California IOU territory. WET incentive programs run concurrently with programs for heat pumps will accelerate the implementation of electrification projects in California's nonresidential buildings. Marketing and education to increase awareness and improve understanding of WET will be crucial; this study's survey, interview, and site visit findings show that the California buildings industry lacks knowledge of WET system benefits and has not yet observed proof of concept at C&I facilities. While numerous case studies in Canada and the United States demonstrate the business case for WET, site visits at IOU customer facilities evaluated the viability of the technology and use cases for C&I properties in California.

Site visits to four C&I buildings helped the research team confirm key inputs for the energy savings model to adjust baselines for WET applications in building types with the greatest potential for impact. The research team identified barriers to efficiency and uncovered solutions to accelerate WET system adoption; they also improved the accuracy of energy savings potential estimates for WET applications in California C&I buildings.

Technology Transfer Tactics

The research team recommends continuing WET research and accelerating technology transfer with a WET system field demonstration. This field demonstration can measure and verify the electricity savings of building-level WET heat exchanger in cooling applications at an industrial or commercial building in California. Site visits from this market assessment uncovered promising opportunities for electricity savings for food processing, office, and healthcare chiller systems.

While WET for heating applications presents TSB, further study could be more complex and necessitate custom approaches. California C&I buildings largely still use natural gas for domestic hot water heating and space heating equipment applications, and a WET heating measure could require a hybrid baseline to characterize efficiency and electrification savings.

Demonstrating WET equipment integrated with a chiller system at an IOU customer facility can provide the data necessary to validate this market assessment's energy model with submetered electricity data from a cooling system in a California building. Calibrated data from a California WET system would inform upgrades to the initial WET energy savings potential calculations and create permutations for each California CZ.

The research team recommends executing a WET field demonstration to achieve the technology transfer goals of this project and the CalNEXT program, provide IOUs with data for measure package development, and boost manufacturer deployment of WET technology in California.

Appendix A: Survey Questionnaire

Facility Details

Please tell us about the building(s) you own or operate.

1. *Which of these options best describes the primary building type of your California property?
 - a. Agricultural (ex. greenhouse)
 - b. Financial (ex. bank branch)
 - c. Education (ex. university)
 - d. Entertainment/Public Assembly (ex. convention center)
 - e. Food Sales & Service (ex. restaurant)
 - f. Healthcare (ex. hospital)
 - g. Lodging (ex. hotel)
 - h. Manufacturing (ex. industrial)
 - i. Multifamily (ex. apartment building)
 - j. Office
 - k. Public Services (ex. library)
 - l. Retail (ex. grocery store)
 - m. Services (ex. auto repair shop)
 - n. Technology/Science (ex. laboratory)
 - o. Warehouse (ex. distribution center)
 - p. Water Reclamation Facility (ex. wastewater treatment plant)
2. *Where is your facility located in California? Enter the nearest city.
 - a. _____
3. When was your facility built? If recently retrofitted, use the year of the most recent major renovation or addition.
 - a. _____
4. What is the gross square footage of your facility?
 - a. _____

Facility Details

Please tell us about your California facility's cooling, space heating, and water heating equipment. Share whether these systems use heat recovery technology (equipment that collects and reuses waste heat for building processes).

5. *Which of these options best describes your facility's primary type of **cooling** equipment? Select all that apply.
 - a. Electric Water-Cooled Chiller
 - b. Electric Air-Cooled Chiller
 - c. Gas Water-Cooled Chiller
 - d. Gas Air-Cooled Chiller
 - e. Packaged Air Conditioners
 - f. Heat Pump System
 - g. Other (please specify)
 - h. None of the above (no cooling)
6. *Does your **cooling** system use heat recovery technology?

- a. Yes (ex. heat exchanger)
 - b. No
 - c. Not sure
7. *Which of these options best describes your facility's primary type of **space heating** equipment? Select all that apply.
- a. Electric Baseboard Heaters
 - b. Heat Pump System
 - c. Gas Boiler
 - d. Gas Unit Heaters / Furnaces
 - e. Gas Infrared Heaters
 - f. Other (please specify)
 - g. None of the above (no heating)
8. *Does your **space heating** system use heat recovery technology?
- a. Yes (ex. heat exchanger)
 - b. No
 - c. Not sure
9. *Which of these options best describes your facility's primary type of **water heating** equipment? Select all that apply.
- a. Electric Resistance Water Heaters
 - b. Heat Pump Water Heaters
 - c. Gas Boiler
 - d. Gas Water Heaters
 - e. Other (please specify)
 - f. None of the above (no hot water heating)
10. *Does your **hot water heating** system use heat recovery technology?
- a. Yes (ex. heat exchanger)
 - b. No
 - c. Not sure

Heat Recovery Details

Please tell us about the opportunities for wastewater heat recovery at your facility.

11. *Please describe the primary sources of wastewater your facility generates. Check all that apply
- a. Sinks
 - b. Showers
 - c. Dishwashing
 - d. Clothes washing equipment
 - e. Toilets
 - f. Industrial process wastewater
 - g. Wastewater treatment plant effluent
12. *Do you treat wastewater on-site?
- a. Yes
 - b. No
 - c. Not sure
13. *Had you heard of wastewater energy transfer or wastewater heat recovery before taking this survey?

- a. Yes
 - b. No
14. *Do you use wastewater energy transfer systems at your facility?
- a. Yes
 - b. No
 - c. Not sure
15. *Would you be interested in saving energy by transferring heat between wastewater streams and your hot water heating, space heating, or space cooling systems?
- a. Yes
 - b. No
 - c. Not sure

Energy Efficiency Details

If you like, please tell us a bit more about your energy goals so that we can ensure efficiency programs are effective at reducing barriers to energy efficiency for building owners and managers.

These questions are optional.

16. What was your facility's natural gas usage for the past 12 months?
- a. _____ therms
17. What was your facility's natural gas usage for the past 12 months?
- b. _____ kWh
18. What are your primary concerns with implementing energy efficiency upgrades?
- c. First Cost of Materials and Labor for Installation
 - d. System Performance
 - e. Training Needed for New Systems
 - f. Labor (availability of resources)
 - g. Other _____
19. If an energy efficiency project is proposed which involves retrofitting existing equipment to reduce energy consumption & costs, what is an ideal payback period that you are willing to consider for the project?
- h. <1 year
 - i. 1 - 2 years
 - j. 2 - 5 years
 - k. 5 - 10 years
20. Are you considering any facility upgrades or energy efficiency improvements?
- a. _____
21. Based on your best estimation, what do you proportion of facility owners/managers like you are using wastewater energy transfer at their facilities?
- a. _____ (value from 0-100)

Appendix B: Site Visit Reports

Site Visit Report #1: Hospital A



Figure 23: Hospital and wastewater pond.

Figure Source: ERI 2025e.

Hospital A operates a five-building healthcare campus in Saint Helena, California. Figure 23 shows the hospital property, which includes the campus of buildings and the property across the street. The facility consists of approximately 150 patient beds, office spaces, operating rooms, facility rooms that operate auxiliary equipment for the site, and storage spaces, and uses two cooling towers, each served by one 450-ton chiller. According to the facility engineer, all sanitary drainage is collected into a wastewater pond approximately one mile offsite, on the property across the street from the campus. This pond also serves residential wastewater loads, collecting sewage from approximately 200 homes in the surrounding area. The facility does not have a centralized wastewater treatment system on the premises. Each building has its own gravity-fed wastewater piping, and the main sewer line—which is also gravity-fed to the wastewater pond—is on the opposite side of the street from the hospital campus.

Wastewater Energy Transfer Potential

Advantages:

- Hospitals have consistent wastewater loads from staff and patients, and WET could serve cooling systems to save electricity and reduce operating costs.

Barriers:

- In order to support a WET efficiency project, Hospital A would need major construction to create a centralized wastewater heat exchanger system. Based on conversations with the facility engineer for Hospital A, the HVAC infrastructure and wastewater piping for the site is also outdated, and would need to be replaced to support a WET system installation.
- The geography of the site is also a barrier for a WET project. Because the facility is on a hillside and the wastewater treatment pond is located far away from the buildings' mechanical rooms, the cost for WET infrastructure would likely be higher than a project that could tap into a closer sewer line for easier heat exchange with wastewater flows.

Site Visit Report #2: Hospital B



Figure 24: Hospital B sanitary pipe and tank.

Figure Source: ERI 2025e.

Hospital B is a 230,000-sq-ft facility located in Bakersfield, California. The facility consists of approximately 250 patient rooms, office spaces, operating rooms, facility rooms that operate auxiliary equipment for the site, and storage space. Approximately 80 percent of the patient rooms are private with attached bathrooms, while the other 20 percent are shared with attached bathrooms.

The facility uses two cooling towers, each served by two chillers. Tower 1 has two 450-ton chillers, and Tower 2 has one 450-ton chiller and one 80-ton chiller.

According to site staff, all sanitary drainage is collected into a centralized tank and then pumped to the city sewage system. The facility is in operation year-round, with waste streams from bathrooms, standalone sinks, and other uses going to the municipal sewer.

Figure 24 above shows that the sanitary piping is accessible within the auxiliary equipment room on the ground floor.

Wastewater Energy Transfer Potential

Advantages:

- Hospital B has a centralized wastewater treatment system that is accessible and could feasibly connect to a WET heat exchanger.

Disadvantages:

- Based on conversations with the building personnel, the space requirements for WET infrastructure may be a barrier, as the mechanical room has dedicated pads for all equipment and only space for approved walkways.

Site Visit Report #3: Food Processing Facility A



Figure 25: Cooling tower area for Food Processing Facility A.

Figure Source: ERI 2025e.

Food Processing Facility A operates a multi-building industrial process in Bakersfield, California. The facility consists of multiple different food processing lines, office spaces, auxiliary equipment rooms, and warehouse/storage spaces, and 6 million gallons of water per day.

The facility uses 19,250,000 kWh per year and has an average monthly peak demand of 2,960 kW. The site engineer said that two processes require cooling the food to approximately 100° F, from temperatures of 140° F and 185° F, respectively. Each process at Food Processing Facility A has its own dedicated cooling tower, one of which is shown in Figure 25. Cooling Tower 1 has a 5-horsepower fan (for the 140° F process) and Cooling Tower 2 has a 7.5-horsepower fan (for cooling the 180° F process water). The facility conducts both processes for approximately 40 hours per week, 52 weeks per year. The site engineer stressed that these towers are working at the top end of their capacity to provide the cooling required for the facility.

Wastewater is sent to an onsite pond used for irrigation; no process water is sent to a municipal sewer system. The site engineer shared that approximately 99 percent of the outgoing effluent is cooled by the cooling tower.

Wastewater Energy Transfer Potential

Advantages:

- Industrial heating processes benefit from WET as a heat sink.
- The site produces consistent wastewater loads from its industrial processes.
- This site can use WET to reduce loads on the cooling tower, as nearly all the water used for industrial processes is ambient or cooled.
- Recovered heat from a WET system could be used to pre-heat industrial process water.

Site Visit Report #4: Commercial Office A

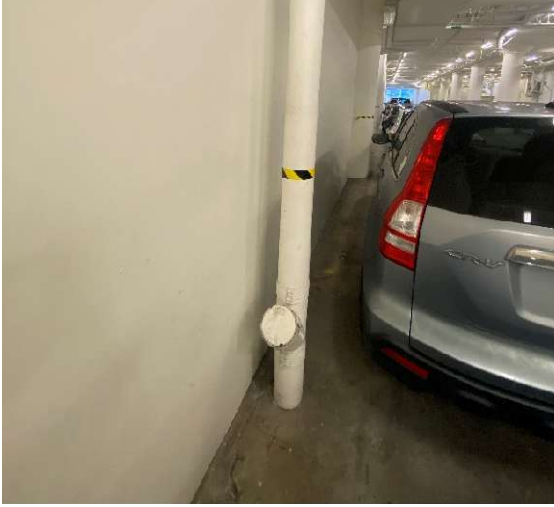

Figure 26: One of four sewer risers in Commercial Office Building A parking garage.

Figure Source: ERI 2025e.

Commercial Office Building A is in San Francisco, California, where it serves as a multitenant facility with over 300,000 square feet of conditioned space. The building was originally constructed to manufacture tanks during World War II, so was constructed using very thick, reinforced concrete. The building includes open-plan office areas, private offices, conference and meeting rooms. Additional support spaces include restrooms on each of the eight floors, storage rooms, a gym on the second floor, and utility areas located throughout the structure. The facility operates year-round, with occupancy and equipment schedules aligned to standard office hours.

The facility uses 46,941 therms per year (4,150,000 kWh per year) and has an average monthly peak demand of 1,070 kW; it is served by three 250-ton chillers with 15-horsepower pumps for chilled water circulation, and 5-horsepower pumps for secondary circulation to their four air handlers. The building's domestic hot water boilers on the roof serve restrooms, kitchenettes, and a small locker room for showers.

Commercial Office Building A's sanitary system is separated into four vertical risers at each corner of the building. The six-inch risers are on the ground floor on each side of the building, where two risers meet underground and go out to the sewer in the front of the building. The west-side sewer run is underneath the lobby area and therefore not accessible, while the east-side sewer line to the street can be seen through repoured concrete patches within the garage; the two vertical risers are visible as well. Based on available space for a potential WET unit, a single six-inch riser would be available for integration into the sewer system.

Wastewater Energy Transfer Potential

Advantages:

- Commercial office buildings have consistent wastewater loads from restrooms, kitchens, and showers.
- Based on conversations with the chief engineer, there is interest in WET technology to supplement the buildings HVAC loads.
- It would be feasible to connect a WET system with a heat pump to serve conference spaces on the ground floor.

Disadvantages:

- Due to access to the sewer system, only one of the four risers would be possible to connect to a WET system's heat exchanger.

References

AECOM. 2025. Personal communication April 28, 2025.

Amer, M.Y., S.K. Salem, M.S. Farahat, A.M. Salem. Reducing drilling cost of geothermal wells by optimizing drilling operations: Cost effective study. Unconventional Resources, Volume 7, 2025, 100196, ISSN 2666-5190, <https://doi.org/10.1016/j.uncred.2025.100196>.
<https://www.sciencedirect.com/science/article/pii/S2666519025000627>

Better Buildings Solutions Center. Wastewater Energy Management Toolkit.
<https://betterbuildingsolutioncenter.energy.gov/wastewater-energy-management-toolkit>

Briggs Equipment Sales. 2025. Daikin Copy. <https://briggsac.com/manufacturer/daikin-copy/>

Building Decarbonization Coalition. 2024. A legislative heatwave: thermal energy network legislation updates (June 2024). <https://buildingdecarb.org/tens-legislation-june-2024>

Building Decarbonization Coalition. 2025. Legislation for Thermal Energy Networks & Pilots
<https://buildingdecarb.org/resource-library/tens-state-leg>

Canadian Securities Exchange. 2025. Clean Energy from an Unlikely Source Catches on Across North America. <https://blog.thecse.com/clean-energy-from-an-unlikely-source-catches-on-across-north-america/>

CBRE. 2025. Chicago Industrial Figures Q1 2025. https://mktgdocs.cbre.com/2299/3b613830-1fa3-4319-9afd-ae3e56b1efab-1367065475/Chicago_Industrial_Figures_Q1_.pdf

California Energy Commission. 2024. 2022 California Commercial End-Use Survey (CEUS): Final Report. https://www.energy.ca.gov/sites/default/files/2024-02/2022%20CEUS%20Final%20Report_ada.pdf

CenTrio Energy. 2025. Our Districts – Chicago. <https://www.centrioenergy.com/our-districts/chicago/>

Chartered Institute of Building Services Engineers. 2021. Energy from waste water – An efficient way to reduce operating costs for heating and cooling. <https://www.cibse.org/media/mnho5wlj/cibse-ne-seminar-waste-heat.pdf>

City of Richmond. 2012.
https://citycouncil.richmond.ca/__shared/assets/Gateway_Theatre_Sewer_Heat_Recovery_System_CNCL_0924201233838.pdf

City of Vancouver. 2025. Sewage heat recovery expansion project. <https://vancouver.ca/home-property-development/sewage-heat-recovery-expansion-project.aspx>

CleanTech Alliance. 2022. Wastewater Energy Transfer: The Benefits and Uses of WET Systems. <https://www.cleantechalliance.org/wp-content/uploads/2022/11/Wastewater-Energy-Transfer-White-Paper.pdf>

Cordia. 2025. A Longtime Provider of Efficient Cooling to San Diego Businesses
<https://cordiaenergy.com/our-networks/san-diego/>

Creative Energy. 2025. Senákw Zero Carbon District Energy System.

<https://creative.energy/projects/senakw>

District Energy Award. 2025. CenTrio Chicago District Cooling System | USA.

<https://www.districtenergyaward.org/centrio-chicago-district-cooling-system-usa/>

Energy Information Administration. 2023. Updated Buildings Sector Appliance and Equipment Costs and Efficiencies. <https://www.eia.gov/analysis/studies/buildings/equipcosts/pdf/full.pdf>

Energy Resources Integration. 2025. California Commercial & Industrial Building Area Analysis.

Energy Resources Integration (ERI). 2025a. California Wastewater Treatment Plants.

Energy Resources Integration (ERI). 2025b. CalNEXT WET Survey Analysis.

Energy Resources Integration (ERI). 2025c. CalNEXT WET Interview Analysis.

Energy Resources Integration (ERI). 2025d. CalNEXT WET Energy Savings Analysis.

Energy Resources Integration (ERI). 2025e. CalNEXT WET Site Visit Reports.

Energy Star Portfolio Manager. 2023. Data Explorer: Site EUI (kBtu/sq. ft.).

https://portfoliomanager.energystar.gov/dataExplorer/?_gl=1*vtajOu*_ga*MTM20Tc3MDAxNy4xNzE4MzAyNjE4*_ga_S0KJTVLQ6*MTcyMDAyNzc3OC4xMi4wLjE3MjAwMjc3NzguMC4wLjA

Financial Post. 2023. <https://financialpost.com/globe-newswire/sharc-energy-applauds-transformative-1-2-billion-development-to-create-2400-affordable-homes-medical-clinic-retail-in-east-new-york>

Find Energy. 2025. Commonwealth Edison. Electricity Rates, Plans & Statistics.

<https://findenergy.com/providers/commonwealth-edison/>

Gautier, A., Michael Wetter, Matthias Sulzer. Resilient cooling through geothermal district energy system, Applied Energy, Volume 325, 2022, 119880, ISSN 0306-2619,

<https://doi.org/10.1016/j.apenergy.2022.119880>.

<https://www.sciencedirect.com/science/article/pii/S030626192201145X>

HUBER. 2021. Energy from wastewater – An efficient way to reduce operating costs for heating and cooling. <https://www.cibse.org/media/mnho5wlj/cibse-ne-seminar-waste-heat.pdf>

HUBER. 2025. Leukerbad in Switzerland uses HUBER Heat Exchanger for heat recovery from thermal spa wastewater. <https://www.huber.cn.com/huber-report/ablage-berichte/energy-from-wastewater/leukerbad-in-switzerland-uses-huber-heat-exchanger-for-heat-recovery-from-thermal-spa-wastewater.html>

HUBER. 2025a. 6 HUBER Heat Exchanger RoWin 14 for the new La Saulaie district in Lyon.

<https://www.huber-se.com/en-us/case-studies/detail/6-huber-heat-exchanger-rowin-14-for-the-new-la-saulaie-district-in-lyon/>

HUBER. 2025b. HUBER ThermWin for what will be the world's largest wastewater-to-energy transfer project at Markham District Energy (Ontario, Canada). <https://www.huber-se.com/en-us/case-studies/detail/official-groundbreaking-ceremony-huber-thermwin-for-what-will-be-the-worlds-largest-wastewater-to-energy-transfer-project-at-markham-district-energy-ontario-canada/>

HUBER. 2025c. First HUBER ThermWin plant for wastewater heat recovery in Switzerland. <https://www.huber-se.com/en-us/case-studies/detail/first-huber-thermwin-plant-for-wastewater-heat-recovery-in-switzerland/>

International District Energy Association. 2024. Markham, Ontario to Build World's Biggest Wastewater Energy Transfer System. <https://www.districtenergy.org/blogs/district-energy/2024/07/25/markham-ontario-to-build-worlds-biggest-wastewater>

International Wastewater Heat Exchange Systems. 2013. https://www.nacleanenergy.com/uploads/product_22459_Case%20Study%20-%20Seven35%202.0.pdf

Koenig, A. What You Need to know About Quoting and Selling Standing Column Well Systems. 2012. <https://blog.heatspring.com/standing-column-well-geothermal/>

Metro Water Recovery. 2025. Request for Proposals for Professional Engineering Study Services PAR 1469 Wastewater Effluent Thermal Energy Recovery and Distribution Study.

Nagpal, Himanshu, Jan Spriet, Madhu Krishna Murali, and Aonghus McNabola. 2021. "Heat Recovery from Wastewater—A Review of Available Resource" *Water* 13, no. 9: 1274. <https://doi.org/10.3390/w13091274>

National Western Center. 2025. Clean Energy from Wastewater. <https://nationalwesterncenter.com/about/what-is-the-nwc/sustainability-regen/energy/>

NYSERDA. 2019. Wastewater Energy Management Best Practices Handbook. <https://www.nyserdera.ny.gov/-/media/Project/Nyserda/Files/Programs/SEM/Best-Practices-Guide-Wastewater-Energy-Management.pdf>

NYSERDA. 2025. Amalgamated Housing Cooperative. <https://www.nyserdera.ny.gov/About/Publications/Featured-Case-Studies/Amalgamated-Housing-Cooperative>

Retrofit Playbook for Large Buildings. 2025. The Towers: Oldest US multifamily co-op transforms wastewater into clean energy. <https://retrofitplaybook.org/resource/the-towers/>

Schmid, F. 2008. Sewage Water: Interesting Heat Source for Heat Pumps and Chillers. <https://etkhpcorderapi.extweb.sp.se/api/file/804>

SHARC Energy. 2018. <https://londoncanada.ashraechapters.org/news19/ASHRAE-2018-09-24-WasteWaterEnergyExchange.pdf>

SHARC Energy. 2022. SHARC Energy gearing to take its first bite of the Big Apple. <https://www.sharcenergy.com/news/press-release/sharc-energy-gearing-to-take-its-first-bite-of-the-big-apple/>

SHARC Energy. 2022a. DC Water Administrative Building.
<https://www.sharcenergy.com/customers/dc-water-hq/>

SHARC Energy. 2022b. SHARC Energy supplies City of Vancouver in the largest Wastewater Energy Transfer project in North America. <https://www.sharcenergy.com/news/press-release/sharc-energy-supplies-city-of-vancouver-in-the-largest-wastewater-energy-transfer-project-in-north-america/>

SHARC Energy. 2025. <https://www.sharcenergy.com/how-it-works/>

SHARC Energy. 2025a. Geothermal and Wastewater Energy.
<https://www.sharcenergy.com/industries-and-use-cases/geothermal-and-wastewater-energy/>

SHARC Energy. 2025b. Alafia. <https://www.sharcenergy.com/customers/alafia/>

SHARC Energy 2025c. Alafia Case Study. <https://www.sharcenergy.com/wp-content/uploads/2025/05/SHARC-WET-Project-Alafia-New-York-Apr-21-2025.pdf>

SHARC Energy. 2025d. DC Water Administrative Building.
<https://www.sharcenergy.com/customers/dc-water-hq/>

SHARC Energy. 2025e. National Western Center. <https://www.sharcenergy.com/customers/national-western-center/>

SHARC Energy. 2025f. seven35. <https://www.sharcenergy.com/customers/seven35-building/>

SHARC Energy. 2025g. Sechelt Water Resource Centre.
<https://www.sharcenergy.com/customers/sechelt-water-resource-centre/>

SHARC Energy. 2025h. False Creek Neighbourhood Energy Utility.
<https://www.sharcenergy.com/customers/sechelt-water-resource-centre/>

SHARC Energy. 2025i. SHARC Energy's WET System Powers Groundbreaking Senákw Energy System.
<https://www.sharcenergy.com/news/press-release/sharc-energys-wet-system-powers-groundbreaking-sen%CC%93a%E1%B8%B5w-energy-system/>

The Energy Mix. 2024. Markham, Ontario to Build World's Biggest Wastewater Energy Transfer System. <https://www.theenergymix.com/markham-ontario-to-build-worlds-biggest-wastewater-energy-transfer-system/>

University Health Network. 2022. UHN breaks ground on world's largest raw wastewater energy transfer system.
https://www.uhn.ca/corporate/News/Pages/UHN_breaks_ground_on_world_largest_raw_wastewater_energy_transfer_system.aspx

U.S. Department of Energy. 2020. District Energy Fact Sheet.
https://www.energy.gov/sites/default/files/2021/03/f83/District_Energy_Fact_Sheet.pdf

U.S. Department of Energy. 2025. Furnaces and Boilers. <http://energy.gov/energysaver/furnaces-and-boilers>

U.S. Environmental Protection Agency. 2017. Water Efficiency Management Guide Mechanical Systems. <https://www.epa.gov/sites/default/files/2017-12/documents/ws-commercialbuildings-waterscore-mechanical-systems-guide.pdf>

Utility Dive. 2024. 30 neighborhood decarbonization pilots allowed under bill passed in California. <https://www.utilitydive.com/news/neighborhood-scale-decarbonization-california-bill-passes-gas-pipelines/726082/>